

# Porsche Carrera Cup France 2021

## Note Technique 04/2021

Chers tous,  
 Veuillez trouver ci-dessous la note technique 04/2021 applicable à votre Porsche 992 GT3 Cup.  
 Nous restons à votre disposition si vous avez des questions.

### MASSES CHASSIS

Porsche Motorsport vous informe que sur votre Porsche 911 GT3 Cup (992), toutes les masses chassis illustrées dans les images ci-dessous doivent être contrôlées et nettoyées avant le premier roulage.

- 1 – Déserrer toutes les masses et contrôler visuellement
- 2 – Nettoyer et poncer les vis au papier abrasif (grain 80)
- 3 – Les surfaces doivent être propres et sans aucune impureté
- 4 – Replacer le faisceau, sans rondelle, et serrer au couple

### GROUNDING POINTS

Porsche Motorsport informs that on all Porsche 911 GT3 Cup (992), all grounding points in picture below must checked and cleaned prior its first event.

- 1 - Loosen all grounding points and check visually
- 2 - Clean and grind all studs with sandpaper (grit size: 80)
- 3 - Surfaces must be clean and free of impurities
- 4 - Refit cable show without washer and tighten with correct torque

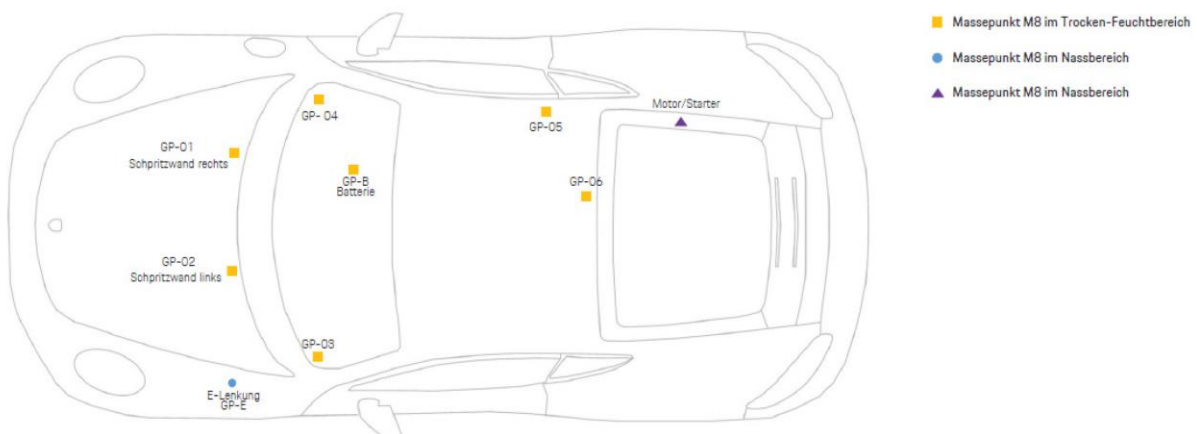

**Masses 01 et 02 (bac avant) // Grounding points 01 and 02 (front section)**

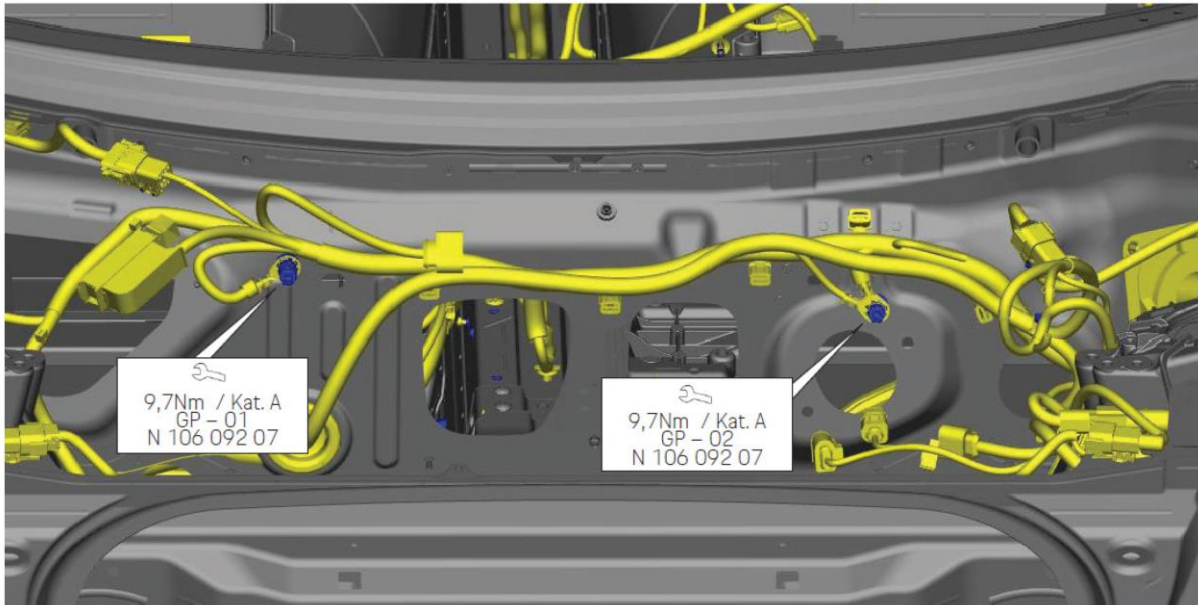

**Masse direction assistée // Grounding point e-steering**

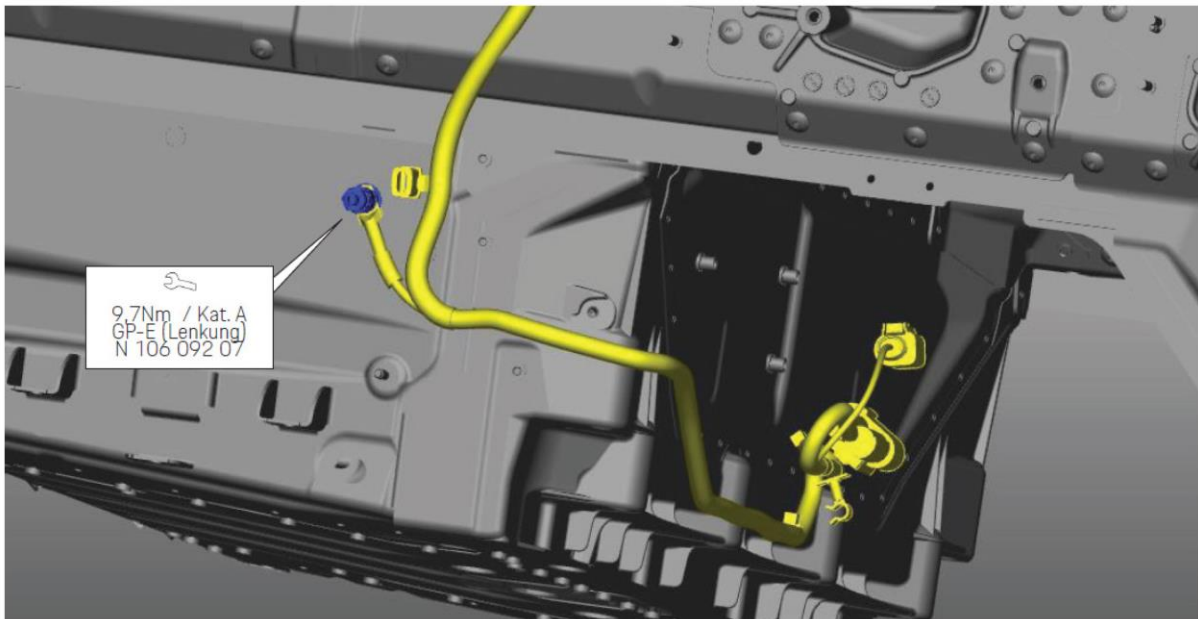

**Masse 03 (repose-pied) // Grounding point 03 (footwell)**

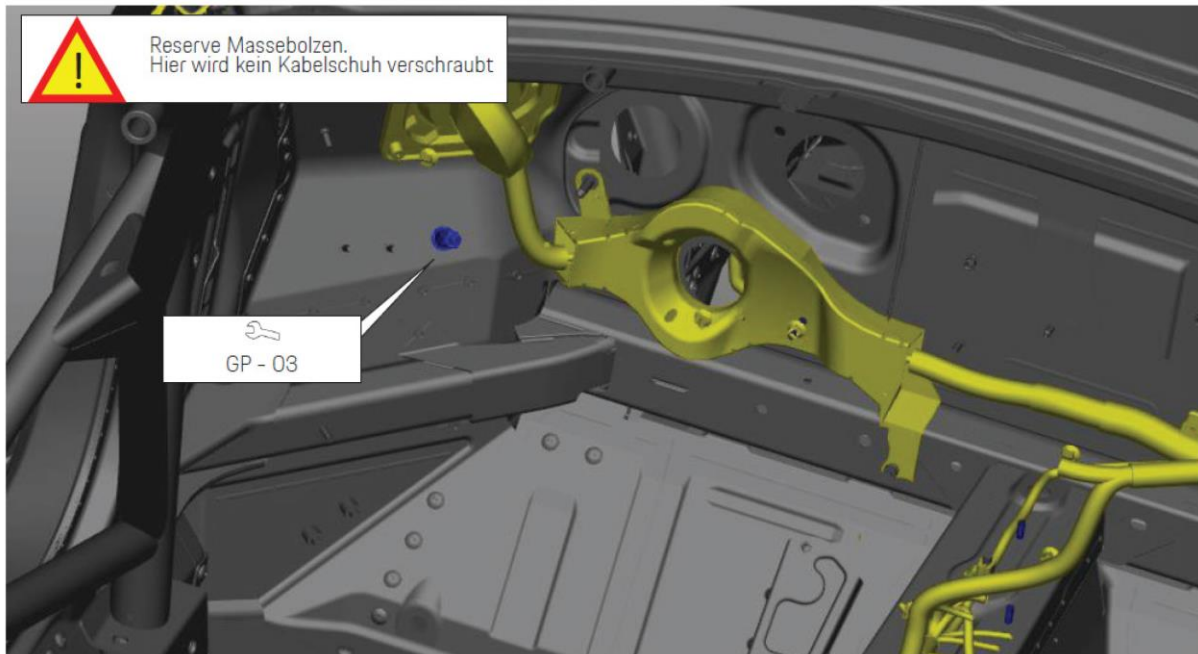

**Masse 04 (repose-pied passager) // Grounding point 04 (passenger footwell)**

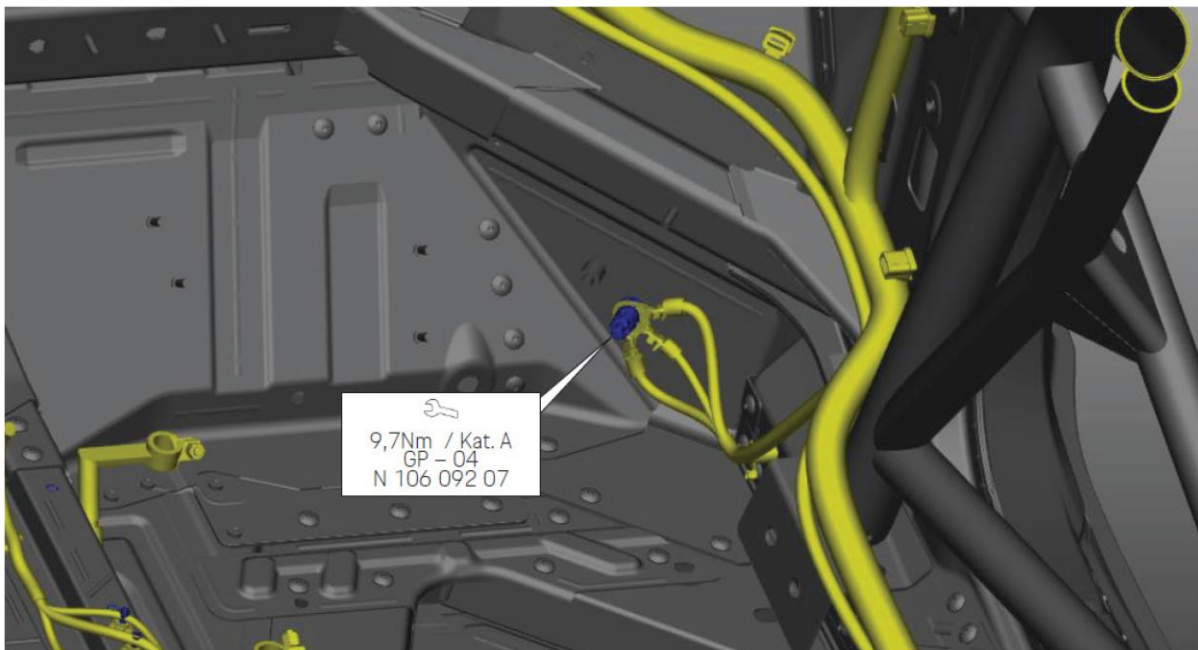

**Masse batterie // Battery grounding point**

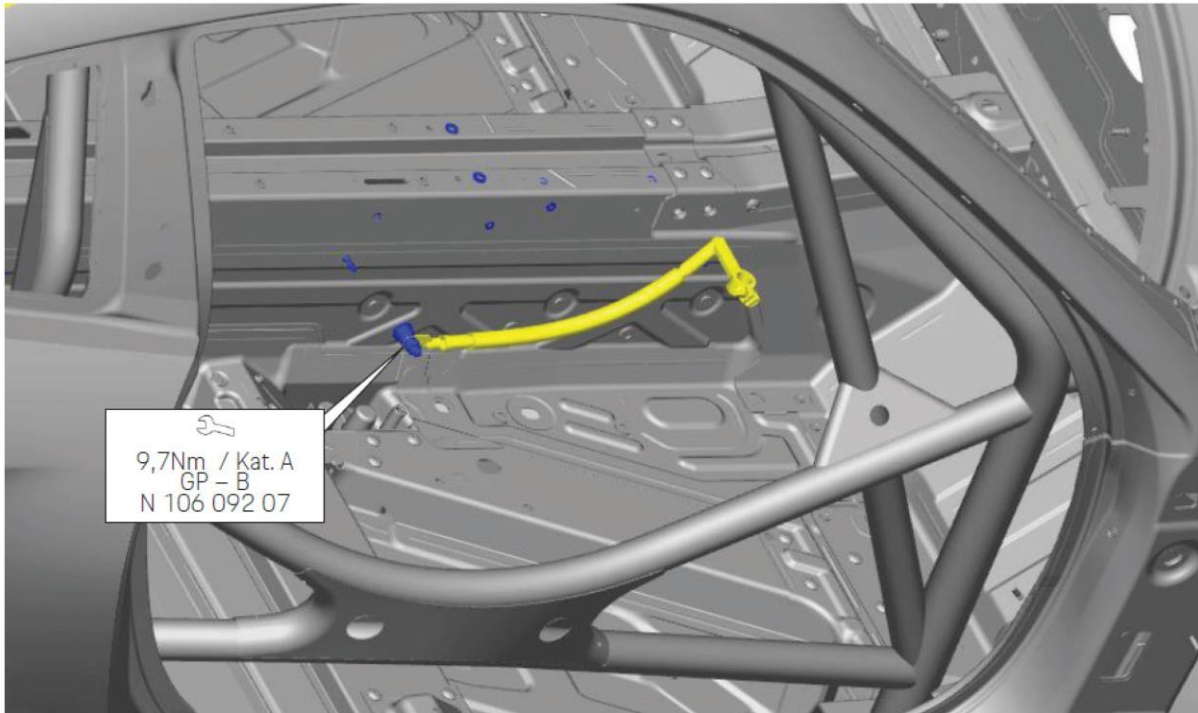

**Masses 05 et 06 // Grounding points 05 and 06**

