

# PORSCHE

CARRERA CUP  
FRANCE



20  
23

## Porsche Carrera Cup France Sporting & Technical Regulations



## Partie 1 : Sporting Regulations

1.	Introduction .....	4
2.	Organisation.....	4
3.	Regulations and legal basis of the series.....	5
4.	Entries and Series Classifications.....	8
5.	Licences.....	13
6.	Insurance, Liability Exclusion and Disclaimer .....	14
7.	Events.....	14
8.	Points for Classification .....	14
9.	Title, prize money & Trophies .....	18
10.	Private practice and testing .....	20
11.	Administrative checks.....	20
12.	Scrutineering / Technical checks.....	21
13.	Running of the competitions.....	23
14.	Protests and Appeals.....	32
15.	Acceptance of the Rules .....	32
16.	Television Rights / Advertising.....	32
17.	Specific Regulations .....	32
18.	Safety .....	39

## Partie 2 : Technical regulations

1.	Technical Series regulations.....	42
1.1	Summary of the eligible groups / classes .....	42
1.2	Principles of the technical regulations.....	42
1.3	General / preamble.....	43
1.4	Driver's Equipment .....	43
1.5	General Regulations.....	44
1.6	Minimum weights and ballast .....	44
1.7	Emissions Regulations.....	47
1.8	Noise Regulations .....	47
1.9	Advertising regulations and starting numbers on the car.....	47
1.10	Safety Equipment .....	49
1.11	Fuel.....	49
1.12	Definitions .....	50

<b>2.</b>	<b>Special Technical Requirements .....</b>	<b>50</b>
2.1	General information .....	50
2.2	Engine .....	51
2.3	Power transmission (gearbox/differential) .....	52
2.4	Lubrication system .....	52
2.5	Brakes .....	53
2.6	Wheel suspension .....	53
2.7	Wheels (flange + rim) and tyres .....	54
2.8	Body and dimensions .....	57
2.9	Aerodynamic devices .....	60
2.10	Electrical equipment .....	60
2.11	Miscellaneous.....	62

## Partie 3 - Appendix

Appendix 1 - 2023 overall and badge Regulations* .....	64
Appendix 2 - 2023 Sticker Regulations* .....	65
Appendix 3 – Ballast weights.....	68
Appendix 4 - Differential lock, ramp angle .....	68
Appendix 5 - Minimum ground clearance, rear and front axle .....	69
Appendix 6 – Seat padding.....	70
Appendix 7 – Part number reference table.....	70
Appendix 8 - Table of Penalty Guidelines.....	71
Appendix 9 – Contacts.....	74

# Part 1: Sporting Regulation

## 1. Introduction

The 2023 Porsche Carrera Cup France, herein after called the Series, is organised by Porsche France which entrusted ORECA with the technical, administrative, sporting and logistics organisation, in conformity with the provisions of the International Sporting Code and its appendices (the Code), the FIA General Prescriptions on circuits and the National Sporting Regulations of the FFSA. It will be run in conformity with these Sporting and Technical Regulations, the latter being in conformity with the safety prescriptions of FIA Appendix J (Article 277). The Porsche Carrera Cup France is an International Series registered to the FFSA with the Silver level.

The Series will be run in accordance with the above regulations. For the avoidance of doubt, should there be any inconsistency or conflict between the individual sets of regulations, then the order of priority shall be firstly those of the International Sporting Code, then the Porsche Carrera Cup France Regulations, followed by the FFSA Regulations. Matters relating to a specific competition will be included within the Supplementary Regulations for the relevant event.

The 2023 Porsche Carrera Cup France consists of five events with two races each and one event with one race, for a total of 11 races. However, the Series Organiser reserves the right to invoke the provisions of Articles 3.2(c) and 13.6 should circumstances mean it is not possible to run all eleven races.

The six meetings of the 2023 calendar will lead to a general classification also called overall ranking and including all competitors. There will also be four other classifications:

- Pro-Am
- Am
- Rookie
- Teams

The Porsche Carrera Cup France is being supported by the following companies\*:

- MICHELIN Compétition
- EXXON MOBIL 1
- SCANIA
- HUGO BOSS
- TAG HEUER

\*Subject to change

Terms used within these regulations such as 'event' and 'competition' are defined as in the FIA International Sporting Code Article 20 (Definitions). Within these regulations, terms referring to natural persons are applicable to all genders.

## 2. Organisation

### 2.1 Series Organiser

Porsche France has entrusted ORECA with the 2023 Porsche Carrera Cup France's organisation. The Organizing Committee consists of members of both Porsche France (CEO, Marketing Director and Motorsport Manager) and ORECA (Porsche Carrera Cup France Manager).

### 2.2 Name of the parent ASN

The Porsche Carrera Cup France is an International Series registered with the FFSA (Fédération Française du Sport Automobile).

### 2.3 ASN Visa/Registration Number

The Series is based on these Sporting and Technical Regulations and has been approved by the FFSA on 04/11/2022 with visa number S/2-2023.

## 2.4 Name of the organiser/promoter, address and contacts

**Porsche France**  
**Christophe Servens**  
Product & Motorsport Manager  
Porsche France  
25/29, quai Aulagnier  
92600 Asnieres-sur-Seine  
Tél : + 33 (0) 6 73 89 87 95  
Mail : [crisophe.servens@porsche.fr](mailto:crisophe.servens@porsche.fr)

**ORECA**  
**Laurie Gautier**  
Porsche Carrera Cup France Manager  
Groupe ORECA  
Siège Social Signes  
83030 Toulon  
Tel : + 33 (0) 4 94 88 98 21  
Mail : [lgautier@oreca.fr](mailto:lgautier@oreca.fr)

### 2.4.1 Organising Committee and Sporting Committee

#### Organising Committee:

The Organising Committee for the Porsche Carrera Cup France competition at each Series event (unless amended in the relevant event Supplementary Regulations) will be:

- Christophe Servens, Product & Motorsport manager – Porsche France
- Laurie Gautier, Porsche Carrera Cup France manager
- Dominik Quosdorf, Technical Support delegate – Porsche AG

Members of the Organising Committee may delegate functions and responsibilities where appropriate to other employees of Dr. Ing. h.c. F. Porsche AG, and Dr. Ing. h.c. F. Porsche AG may nominate additional members of the Organising Committee where necessary.

#### Sporting Committee:

A Sporting Committee for the Series will be established comprising of the following people or their nominated representatives:

- The Series Organiser (members of Porsche France and ORECA),
- The Permanent Race Director,
- The Series Technical Support Delegate

The role of the Sporting Committee will be to resolve any issues arising in respect of interpretation or application of the Series Sporting and Technical Regulations and will include taking decisions on:

- Any questions concerning points or the classification of the Series,
- Any matters arising from the Series Regulations which are not specific to an individual event.

Decisions taken by the Sporting Committee shall be final and are not subject to protest or appeal.

## 2.5 List of permanent Officials

Race director\*: Jean-Yves Munster

Deputy Race Director: Matthieu Moreau

Chairman of the stewards: TBA

*\* If a change of official is required at a meeting, the name of the substitute official will be indicated in the supplementary regulations of the event.*

## 3. Regulations and legal basis of the series

The Series is governed by the following regulations:

- FIA International Sporting Code (ISC) and its appendices,
- 2023 Sporting and Technical Regulations of the Porsche Carrera Cup France and FFSA approved modifications or supplements (addendum),

- Supplementary Regulations for Series events including modifications and supplement issued by the FFSA or the Stewards of the competition (bulletins). Where any aspect of the Sporting Regulations must be adapted for a specific event, the provisions of the Supplementary Regulations for that event will take precedence over the Sporting Regulations of the Series,
- Regulation of each track where the Porsche Carrera Cup France is going,
- FIA General Prescriptions on circuits,
- FFSA Licence Regulation,
- Anti-Doping Regulations of the National and International Anti-Doping Agency (NADA Code/WADA Code) as well as the Anti-Doping and Anti-Alcohol Regulations of the FIA,
- The Entry form Driver Season / Guest / Substitute Driver" signed by the entrant/driver,
- FIA Code of Ethics and Porsche Carrera Cup France's Code of Behaviour (Art. 3.3),
- Other FIA and FFSA regulations as applicable.

### **3.1 Official language**

For these regulations of the Porsche Carrera Cup France only the French text approved by the FIA/FFSA is binding.

### **3.2 Responsibility, changes to the rules of participation, cancellation of the event**

(a) The participants (Competitors, Drivers, car owners, team members, registered keepers and team guests) attend and take part in any Series event at their own risk. They are solely responsible under civil and criminal law for any and all damage caused by them – or for damage to the cars used by them, as far as no exclusion of liability has been concluded.

(b) The Supplementary Regulations for Series events may only be changed by the ASN of the event. Once the event starts, changes in the form of bulletins may only be made by the Stewards.

(c) The Event Organiser and the Series Organiser reserve the right to cancel or relocate an event or individual race, subject to approval by the ASN concerned and the FIA where the calendar is affected. Claims for damages or performance shall be excluded in all such cases.

Obvious errors can be corrected at every time. The FFSA agreement is mandatory to modify any part of the regulation. Regulations can be imposed in written by the series organiser and the technical scrutineer with FFSA agreement or official event's stewards.

The FFSA, the Series Organiser and the meeting organiser reserve the right to modify the rules of participation and the General Regulations, if necessary, for reasons of force majeure, for safety reasons, or to ensure equal opportunities and the attractiveness of the Series.

### **3.3 Porsche Carrera Cup France code of conduct**

The Porsche Carrera Cup France is a Series characterized by equality of opportunity and fairness – in both technical and sporting terms. All those involved in the Series (participants, teams with all employees and team members, drivers, officials, organisation) make a significant contribution to how the Series and by extension including the Porsche brand, is perceived – both internally and by the general public – and to the atmosphere in the Porsche Carrera Cup France through their conduct and their communication.

All those involved are responsible for conducting themselves in such a way as to uphold and safeguard in the long term the professionalism that prevails in the Porsche Carrera Cup France, as well as the esteem in which the Series, the Porsche brand and its participants are held within motorsport and by the general public. Moreover, fair and sporting competition represents an important safety aspect for all participants and is intended to minimise the risks involved.

For this reason, all those involved agree to acknowledge the philosophy of the Porsche Carrera Cup France and to comply with the rules of conduct of the Series.

Both on and also off the racetrack, all those involved will:

- Treat all participants, officials and organisers respectfully,
- Follow the laws and the rules of the sport, exemplify and promote fairness together with the rules of conduct,
- Neither express themselves or behave in an insulting, offensive or abusive way, nor tolerate such expressions or modes of conduct, either in direct conversations, interviews, etc. or in other communication, e.g. press releases, posts in social media, etc.
- Always behave in the interests of safety and permanently cooperate in efforts to reduce risks,
- Use resources in a sustainable way, giving priority to the well-being, safety and satisfaction of others before their own personal goal,
- Always comply with the purpose of the sport,
- Inform those who are involved if their conduct is not characterised by fairness, sportsmanship, respect and tolerance.
- Cooperate with all other persons involved so as to develop and improve the Series and its status further on a continuous basis.
- Respect the laws and local customs in the countries visited by the Series.

Participants who are found to have committed one or more of the following may be excluded by the Series Organiser from the Series or may be suspended or disqualified by the Stewards from taking part in one or more competitions:

- Failed to comply with the rules of conduct
- Breached any of the Regulations,
- Drawn attention to themselves through unsporting behaviour on and off the track,
- Expressed themselves or behave in a disrespectful way towards other participants, officials, organisers, etc.,
- Ignored the specifications, instructions, meetings of the Series organisation and/or other official bodies in the context of the organisation and holding of an event,
- Ignored agreements that had been reached (including between Competitors, teams and drivers) and did not meet obligations of performance,
- Did not act in the interests of the sport and/or the recognizable objective of undertaking the activities seriously in accordance with the rules that have been acknowledged,
- Brought discredit to the Series and to the Porsche brand.

These participants may therefore be disqualified from the Porsche Carrera Cup France. The decision will be taken by the Sporting Committee. Any decision of the stewards regarding the above is not subject to appeal.

Where a fine is imposed, continued participation in the Series may not be permitted until any fine imposed is paid in full.

Specific mandatory requirements or restrictions in respect of behaviour of participants, or specific conditions of participation, may be published by the Series Organiser in order to minimise the risks of, and maximise protection against epidemics.

These will be set out in the official documents published by the Series organizer (available from the Series organizer). It is essential that these requirements are followed by all participants and any breach of these requirements would be deemed a serious infringement of the Porsche Carrera Cup France of Conduct (Art 3.3).

Competitors (entrants) are responsible for ensuring full compliance by every person associated with their entry at all times during every applicable event.

## **4. Entries and Series Classifications**

### **4.1 Registrations and entries, closing date and obligation to participate**

Porsche Carrera Cup France entries are based on an invitation system.

However, an application for entry to the Porsche Carrera Cup France must be submitted by a competitor using the official "Entry Form" (as supplied by the Series Organiser) and must be received by the Series Organiser by February 01<sup>st</sup>, 2023. If a completed "Entry Form" is received after this date, it may only be considered at the sole discretion of the Series Organiser.

The Competitor will receive a confirmation if his "Entry Form" has been accepted. There is no automatic entitlement to acceptance or participation in the Series.

The Series Organiser reserves the right to refuse an "Entry Form" at his own discretion, stating the reason.

In order to meet the deadlines for the receipt of an "Entry Form" the application must be submitted to the Series Organiser fully completed and signed. The "Entry Form" must be signed by the Driver and the Competitor.

The documents must be sent to the following address: [lgautier@oreca.fr](mailto:lgautier@oreca.fr)

This registration obliges the driver to participate to all races of the championship and to the Official Tests Day with a register vehicle.

With the submitted "Application for Driver Entry" the driver must specifically indicate if he wishes to participate in the "Pro", "Pro-Am", "Am" classification.

Notwithstanding acceptance of any "Entry Form", permission to participate in any Series competition is always subject to the satisfactory completion of the scheduled licence verification procedure at the relevant event.

To score points in the Team Classification, each team will have to enter their cars under its own international "Team" licence. Each competitor (Team) will have the possibility to enter all their cars under his own "Team" licence.

However, a competitor (Team) entering more than 2 cars must designate 2 cars before each event in order to score points in the Team Classification. This designation must be made by the team manager during the administrative checks of each meeting.

A team entering more than four cars is free to have two team licences. The second team will score points under the same conditions as the first.

### **4.2 Driver classifications of the Series**

Only drivers registered for the season will be included in any of the final classifications of the Series.

#### **4.2.1 Overall Classification**

The overall classification is the official driver championship classification of the Series.

#### **4.2.2 Categories**

The Championship will have three categories:

- Pro (Professional)
- Pro-Am (Professional-Amateur)
- Am (Amateur)

Any individual interested in participating in the Championship as a driver shall indicate on their Entry Form the category in which they believe they should participate.

Porsche will review each individual's selected Category and decide whether to accept that selection. The criteria applied by the Series Organizer in making this decision will include the potential driver's "sporting spirit", past performances, professional profile, age and any other criteria that Porsche will consider useful to consider.



"Pro", "Pro-Am" and "Am" drivers are not allowed to share their car during a meeting.

The Series organiser has the final decision in the allocation of drivers to the respective categories.

The Series Organiser reserves the right to modify a driver's category during the season. The driver will be notified and the decision cannot be contested.

#### **4.2.3 Pro-Am & Am Classifications**

The Pro-Am and Am Classification is a separate classification for drivers without a professional motorsport background.

Participation is based on the sporting résumé of a driver and requires written approval of the Series Organiser.

Points are allocated identically to the point system of the Overall Classification.

Please note that the "Am" category must have a minimum of 3 drivers registered for the season. If not, the "Am" drivers will be reclassified in the "Pro-Am" category. The end-of-season prizes linked to the " Am " classification will also be cancelled.

The Series Organiser reserves the right to amend the allocation of the number of drivers to both classifications.

#### **4.2.4 Rookie Classification**

A "Rookie" is a driver contesting his first season in the Porsche Carrera Cup France and has not participate in more than 3 races of any Porsche Carrera Cup, GT3 Cup Challenge and/or Porsche Mobil 1 Supercup before the first race of the Porsche Carrera Cup France 2023 season.

Only drivers registered for the whole season will be classified.

The maximum age for participation in the Rookie Classification is 25 years (the Driver must not have reached their 26<sup>th</sup> birthday by the closing date for the submission of entries February 1st, 2023).

#### **4.2.5 Porsche Junior**

A Porsche Junior driver is a driver officially nominated and supported by Porsche AG and who has successfully completed the Porsche AG selection process.

Only Porsche Juniors are permitted to use the Porsche Junior branding and labels.

Only one Porsche Junior can be registered as a driver per competitor, irrespective of the number of team licences and entered cars.

#### **4.2.6 Guest teams**

The Series Organiser may permit Guest Teams to participate in one or more rounds of the Series. Guest teams may take part without being eligible for points for the Team Classification on condition that they comply with the conditions of the Sporting and Technical Regulations of the Series and the Supplementary Regulations of each event.

Guest Teams should apply for participation in a single competition no later than 14 days prior to the start of the relevant competition using the "Guest Entry Form" (as supplied by the Series Organiser). The Series Organiser reserves the right to accept or reject the "Guest Entry Form" that arrives after this time limit.

The Competitor will receive a written confirmation if his entry form has been accepted. The Series Organiser reserves the right to refuse an Entry Form, at its own discretion, stating the reason. There is no automatic entitlement to acceptance or participation in the Series.

Any car previously entered by a Guest Team may retain its competition number if entered again later in the same Series.

The Series Organiser reserves the right to enter cars under its own "Guest Entry Form" as Guest Team.

#### **4.2.7 Substitute drivers**

Substitute drivers can apply to compete at individual race events by filling the "Entry Form – Substitute Driver" until 14 days before the meeting at the Porsche Carrera Cup France Organisation.

Substitute drivers may only participate with a permanently entered car under an already existing starting number in the championship. This restriction may be removed at the discretion of the Series Organiser.

The replacement of a driver is not subject to driver categorisation (a Pro driver can replace a Pro-Am or Am driver and vice versa).

Substitute drivers will score points according to their results and they will be eligible for prize money during the first 4 meetings of the season. During the last two meetings of the season (races 9 - 10 - 11 - 12), substitute drivers will not score point (nor pole position and fastest lap points) and they will not be eligible for prize money.

Substitute drivers will not be eligible for the best lap award.

#### **4.2.8 Guest drivers**

The Series Organiser may permit Guest Drivers to participate in one or more competitions of the Series. Guest Drivers may take part without being eligible for points for any Driver Classification on condition that they comply with the conditions of the Series Regulations and of the Supplementary Regulations for the relevant event.

Guest drivers will not be awarded points and prize money but may participate in any podium ceremonies as applicable. A Guest driver finishing 3<sup>rd</sup> then the 4<sup>th</sup> driver (who is registered for the whole season) will score the 3<sup>rd</sup> place points.

Guest Drivers should apply for participation in single competitions no later than 14 days prior to the start of the relevant competition using the "Entry Form – Guest Driver" (as supplied by the Series Organiser). This entry form must be sent to the Series Organiser.

The Series Organiser reserves the right to accept or reject the "Entry Form" that arrives after this time limit. The entry fee is due as indicated in the "Entry Form – Guest Driver".

The Competitor will receive a written confirmation if his Guest Driver has been accepted. The Series Organiser reserves the right to refuse an "Entry Form" at its own discretion, stating the reason. There is no automatic entitlement to acceptance or participation in the Series.

For each participation, the Competitor will be asked to fill this entry form, without this one the competitor/driver can't take part in the meeting.

Guest Drivers may only participate with a car that is entered a single competition and without a previously existing competition number for the entire Series. If a Guest Driver enters for a second or further competitions, he may use the same car as before, provided that the car has been entered again for a single competition. Guest Drivers may participate in a car that has been used by a previous Guest Driver with the same or different competition number.

Priority in the acceptance of entries will be given to the Competitors registered for the season.

The minimum licence required to take part in the Porsche Carrera Cup France is FIA International Grade C issued by an FIA-affiliated ASN and valid for 2023.

The Series Organiser reserves the right to enter a Guest driver under its own "Porsche Carrera Cup France" application.

The Series Organiser also reserves the right to permit additional Guest Entries to individual classification competitions.

The Series Organiser reserves the right, at its sole discretion, to permit Guest Teams and/or Guest Drivers to participate in the official season test(s). If permitted, this will be subject to certain conditions and/or costs which will be specified separately by the Series Organiser. No Guest Teams or Drivers will be permitted at the Season Roll-Out, where there is one, with the sole exception of Guest Drivers entered by the Series Organiser.

## **4.3 General Entry Terms & Obligations**

### **4.3.1 Commitment to participate**

#### **Competitor obligation:**

Upon registration for the whole season, a Competitor undertake to participate with each registered car in all official season tests and all races of the Series in 2023 without exception.

#### **Failure to participate:**

Any competitor or driver registered for the whole season who fails or anticipates failing to fulfil these participation requirements must inform the Series Organiser in writing at the earliest opportunity, stating any mitigating reasons.

The Series Organiser may at their sole discretion accept a request for non-participation from a competitor and/or driver. Any failure to inform the Series Organiser or to submit any mitigating reasons may automatically be deemed a contravention of these Regulations. The Series Organiser may request the Stewards to penalize a failure to non-attendance.

Failure to participate may result in a fine of at least EUR 5,000 ex-VAT per car and/or driver. The Stewards of the event shall decide whether the Competitor and/or driver shall be subject to a penalty, taking into consideration if the Series Organiser has previously received and accepted a request for non-participation from the Competitor and/or driver. This fine will be charged to the team entering the car for the season or the race if applicable.

### **4.3.2 Authorisation**

With the submission of the "Application for Driver Entry", competitors and drivers authorize the Series Organiser to submit entry forms on their behalf for those events which host races which form part of the Series in 2023. Direct nominations to the promoters by the participants are not permissible. That is to say that only the registrations sent and validated by the Series organizer are valid.

The competitor/driver agrees that Porsche AG, whose representatives constitute the Organising Committee for each Competition, has access to and authority to utilise the reports, data and document of the Technical scrutineers at all times.

### **4.3.3 Driver transfers between teams**

Any driver wishing to transfer from one Competitor to another must complete an "Entry Form" and submit it to the Series Organiser.

A driver may transfer from one team (competitor) to another during the season but having done so may not transfer back to the original team (competitor).

A driver transferring to another team (competitor) may not use the same competition number, but instead must use either the number of a car already entered by the new team (competitor) or a new number if a new car is being entered by the competitor. As the tyres are allocated to the race number, the former team will retain possession of them.

The race number may be assigned by the Series organiser.

The driver will keep his points scored in the driver classification with his former team.

For the Team classification, points scored by this driver, if he has been designated as scoring points, remain with the original team.

### **4.3.4 Replacement of cars, engines, gearboxes or engine control units**

A team (competitor) may not replace a car that has already been entered and allocated a competition number, unless the car has suffered significant or irreparable damage at a preceding event or during an event.

### Replacement of cars during an event:

The competitor must make a written request to the Stewards seeking permission to use a replacement car and it shall be at the sole discretion of the Stewards whether to accept or reject the request.

Where the Stewards accept such an application, that acceptance may be given subject to specific conditions. Where the replacement of a car is accepted after Qualifying it will be normally be on condition that the car starts the race from the back of the grid.

### Replacement of cars between events:

Any change of cars between events must be approved in advance by the Series Organiser in writing.

The Competitor must request such a change in writing (electronically signed) prior to the event where the replacement car will be used.

The Competitor will receive a written confirmation (electronically signed) if the change has been approved. It shall be at the sole discretion of the Serie Organiser whether to accept or reject the application.

### Replacement of cars, engines, gearbox or ECU

Any change of engine, gearbox or ECU between events or during an event must be approved in advance by the Series Organiser in writing.

The Competitor must request such a change in writing (electronically signed) and he will receive a written confirmation if the change has been approved. It shall be at the sole discretion of the Serie Organiser whether to accept or reject the application

## 4.4 Entry fees

### 4.4.1 Entry fee for the season

The entry fees\* (based on the six rounds of the championship) costs **24 000€** (ex-VAT).

	Advantage	Price
1 <sup>st</sup> et 2 <sup>nd</sup> cars	Entry fee: 100%	24 000€ ex-VAT each car
3 <sup>rd</sup> car	Entry fee: 50%	12 000€ ex-VAT
4 <sup>th</sup> car	Entry fee: 25%	6 000€ ex-VAT
5 <sup>th</sup> car and 6 <sup>th</sup>	Entry fee: 100%	24 000€ ex-VAT each car

The entry fee includes the following services:

- Entry for one car for the six meetings of the championship
- Official Test Day at Magny-Cours of 30<sup>th</sup> March 2023.
- 6 paddock passes per event per car\*\*
- 6 pitlane passes per event per car\*\*
- 4 parking passes per event per car\*\*
- Free practices fees, ASN rights, boxes fees and transponders if concerned
- 1 - 2023 Porsche Carrera Cup France official racing suit & accessories
- The catering pack for the driver for each meeting

\*Registration fees cannot be split or refunded.

\*\* Number of passes can change according to the meetings.

The Entry fee will be invoiced, plus value added tax as effective by law, by Porsche France after assessing the "Entry Form". The invoice is not a confirmation of acceptance of the "Entry Form".

Force majeure, labour disputes, civil disturbances, action by official bodies and other unforeseeable, unavoidable and serious occurrences, in particular restrictions and measures due to epidemics, shall release the Series Organiser from his duties to perform regarding the aforementioned scope of services. In case of cancellation of services, the Series

Organiser will accordingly try to compensate the cancelled services with other services or refund a reasonable part of the entry fee to the competitor.

If attendance at any event(s) has to be limited to essential personnel only, it will be necessary to restrict the provision of tickets and passes accordingly. If so, the Series Organiser will notify Competitors of the number of passes which will be made available for the applicable event(s).

#### **4.4.2 Entry fees per competition\***

The Guest Entry fee per car is 5 000€ (ex-VAT). Except for the Le Mans event.

The entry fee includes the following services:

- Entry for one car for the one meeting of the championship
- 6 paddock passes per event per car\*\*
- 6 pitlane passes per event per car\*\*
- 4 parking passes per event per car\*\*
- Free practices fees, ASN rights, boxes fees and transponders if concerned
- The catering pack for the driver for each meeting

*\*Registration fees cannot be split or refunded.*

*\*\* Number of passes can change according to the meetings.*

The Entry fee will be invoiced, plus value added tax as effective by law, by Porsche France after assessing the "Entry Form". The invoice is not a confirmation of acceptance of the "Entry Form".

### **4.5 Competition Numbers**

Drivers are free to choose their race number. If two drivers ask for the same number, priority will be given to the driver who has sent his entry form first.

The competition number of the car will be communicated to the team/driver before the first race. Once a competition number has been assigned to a car, the number will remain with that car for the remainder of the season and, if a change of chassis is necessary, the number (and corresponding tyre allocation) will be transferred to the new chassis.

The Series Organiser reserves the right, in exceptional circumstances, to reassign allocated competition numbers ahead of the first event.

## **5. Licences**

### **5.1 Licence requirement**

#### **▪ Drivers**

Drivers must hold a valid International driver's licence for 2023 issued by the FFSA or by another FIA-affiliated ASN, of Grades

- International Licence Grade A (IT-A)
- International Licence Grade B (IT-B)
- International Licence Grade C (ITC-C)

#### **▪ Competitor**

Competitors (Team) wishing to register with the Series must be in possession of a valid International Competitor's licence issued by an FIA-affiliated ASN and have paid the registration fees.

#### **▪ Age regulations**

In compliance with the FIA International Sporting Code, no driver under 16 years old will be permitted to enter the Series.

## 5.2 Conditions for competitors outside their national territory

For events with the status International, the FFSA licence holders and licence holders by another ASN affiliated to the FIA have the right for participation and are entitled to score points for the series.

For every competition foreign Competitors/Drivers must present the written authorisation of their own ASN.

Foreign applicants/drivers require the approval of their own ASN in compliance with article 3.9.4 of the ISC excepted if their licence clearly state all FIA-approved competition entering is allowed and for which the licence is valid.

## 6. Insurance, Liability Exclusion and Disclaimer

### 6.1 Organiser's/promoter's insurance

The insurance company and policy number will be stated in the Supplementary Regulations for each event.

### 6.2 Declaration by the competitor, driver on the exclusion of liability, disclaimer of the car owner

In accordance with FFSA Regulations.

## 7. Events

### 7.1 Calendar of events\*

The 2023 Porsche Carrera Cup France consists of 11 races organised as circuit races.

2 races will be scheduled at each meeting except for the Le Mans round where there will be only one race.

Official Tests Magny-Cours		March, 30 <sup>th</sup>	Mandatory
<b>Barcelona</b>	<b>ELMS</b>	<b>April 21<sup>st</sup> - 23<sup>rd</sup></b>	<b>2 races</b>
<b>Magny-Cours</b>	<b>FFSA GT</b>	<b>May 05<sup>th</sup> - 07<sup>th</sup></b>	<b>2 races</b>
<b>Le Mans</b>	<b>24 Heures du Mans</b>	<b>June 06<sup>th</sup> - 10<sup>th</sup></b>	<b>1 race</b>
<b>Red Bull Ring</b>	<b>GT Open</b>	<b>September 08<sup>th</sup> - 10<sup>th</sup></b>	<b>2 races</b>
<b>Monza</b>	<b>GT Open</b>	<b>September 22<sup>nd</sup> - 24<sup>th</sup></b>	<b>2 races</b>
<b>Paul Ricard</b>	<b>FFSA GT</b>	<b>October 06<sup>th</sup> -08<sup>th</sup></b>	<b>2 races</b>

\*Subject to final confirmation

### 7.2 Maximum number of vehicles authorized

The maximum number of cars allowed is determined by the licences of each circuit.

The maximum number of cars will be announced in each event regulation.

## 8. Points for Classification

The winner of a race is the driver who has covered the longest distance with his/her vehicle within the duration of the race, taking all penalties into account.

### 8.1 Awarding of points

All drivers who started the race will be classified in accordance with the number of laps of the circuit covered providing that they have achieved at least 75% of the number of laps achieved by the winner (rounded down to the nearest whole lap) without having to pass the checkered flag.

Drivers who have completed the same number of laps of the circuit will be classified in the order in which they have crossed the control (timing) line.

In case of race interruption, the race duration will be the time between the start of the race and the moment where the leader achieves his last lap before the race interruption.

If the race is shortened or stopped and cannot be resumed the participants will be awarded the points as indicated below, providing that at the time the race is stopped, the leader has covered:

- If at least 50% of the original race time in minutes is achieved, 100% of the points will be awarded.
- If less than 50% of the original race time in minutes, 50% of the points will be awarded

If a race is stopped before the leader has finished two complete racing laps (the race is therefore declared null and void) and cannot be restarted, or a race cannot be started at all, then 50% points will be awarded on the basis of the Qualifying Final Classification. The Stewards may disallow the points awarded to any Driver who they deem responsible for causing the stoppage of a race which is then declared null and void and cannot be restarted. If there has also been no Qualifying Classification, then no points will be awarded.

The time covered by the leader is time lapse between the beginning of the race (green flag/lights) and the moment when the leader crossed the control line of his last complete lap before the race interruption. No additional time/laps are added to the race distance if the Safety Car is used at any time in a race.

All laps of the circuit covered after starting the race shall be calculated to obtain the race duration covered. The warm-up, formation and cool down laps do not count towards this duration.

### **8.1.1 Overall Classification**

All the results of the individual races count towards the final classification at the end of the season, there are no void or "dropped" results. The winner of the 2023 Porsche Carrera Cup France is the driver with the highest total number of points in the overall classification from all the races.

The Pro-Am / Am and Rookie Classification are listed separately. The winner of each classification is the driver with the highest total number of points of all races.

For the avoidance of doubt, drivers will score points according to their places in the final race results; this will be irrespective of whichever classification they are in. Points will be awarded in accordance with the "Table of Points" as set out in article 8.2.

It is permitted for a Driver to change teams and/or vehicle during the season (subject to Article 4.3.3) and to continue scoring points for the Drivers' championship (Overall / Pro-Am / Am / Rookie).

Guest drivers will not be awarded points for the drivers' rankings (Overall / Pro-Am / Am / Rookie) and they are not eligible for any prize money. But they may participate in any podium ceremonies as applicable.

Drivers registered for the whole season classified behind Guest drivers in the race results from an event will move up within the Driver ranking accordingly.

Substitute drivers will score points and receive prize money based on their results during the first fourth meetings, so except for the 5<sup>th</sup> and 6<sup>th</sup> meetings of the season (races 8 – 9 – 10 – 11). During the last two meetings of the season (races 8 – 9 – 10 – 11), substitute drivers will not score point, and they will not be eligible for prize money. The substitute driver's car entered during the season will score points in the Team ranking only during the first fourth meetings.

### **8.1.2 "Pro-Am" Classification**

The "Pro-Am" classification is independent to the Overall Classification.

Points for the Pro-Am Classification will be awarded separately using the same 'Table of Points', hence the highest placed Pro-Am Classification driver will be awarded 25 points in the Pro-Am Classification, and so forth.

In addition, an extra point for pole position and for the best lap in the race is awarded for riders in this category.

It is permitted for a driver to change teams during the season and to continue scoring points for the Pro-Am drivers' championship.

The only difference is that only the 9 best race results will be taken into account for the "Pro-Am" Classification. The 2 worst best results will be dropped (excluding best laps and pole position). If a driver is absent from the last two races (races 10 and 11), his non-participation will not be taken into account in the final counts.

A disqualification or penalty leading to a void result will not be counted.

If the "Am" Category has less than 3 drivers, "Am" drivers will be classified in the "Pro Am" Category. Any

### **8.1.3 "Am" Classification**

The "Am" classification is independent to the Overall Classification.

Points for the Am Classification will be awarded separately using the same 'Table of Points', hence the highest placed Am Classification driver will be awarded 25 points in the Am Classification, and so forth.

In addition, an extra point for pole position and for the best lap in the race is awarded for riders in this category.

It is permitted for a driver to change teams during the season and to continue scoring points for the Am drivers' championship.

The only difference is that only the 9 best race results will be taken into account for the "Am" Classification. The 2 worst best results will be dropped (excluding best laps and pole position). If a driver is absent from the last two races (races 10 and 11), his non-participation will not be taken into account in the final counts.

A disqualification or penalty leading to a void result will not be counted.

Please note that the "Am" category must have a minimum of 3 drivers registered for the season. If not, the "Am" drivers will be reclassified in the "Pro-Am" category. The end-of-season prizes linked to the "Am" classification will also be cancelled.

### **8.1.4 Team Classification**

The team classification is independent from the driver classification.

A team wanting to score points in this classification, must enter their cars under its own licence (Team). Each team must be in possession of a "Competitor" licence. Only one licence per team can be taken into account.

Only the points of two cars entered under the same licence of a team are added together for the team ranking. The points of two cars entered under the same competitor licence are added for the team ranking.

Points for the Team Classification are awarded according to the official overall race result, irrespective of the several categories.

If there are more than two cars entered under one Competitor licence, the Competitor must nominate a maximum of 2 cars before each event to score points in the Team Ranking. This designation must be made by the team manager during the administrative checks of each meeting.

Should the Competitor fail to nominate two drivers, then the two respective drivers with the lower two competition numbers (the lowest number being 1) will be nominated automatically for that competition by the Series Organiser. No other cars from that Competitor will be considered for the Team Classification.

Points towards the Team Classification will be awarded according to the driver classification system (Article 8.2), taking into account the points from pole positions and fastest laps during the race.

Substitute driver may be nominated to be eligible for team points scoring but only for the first four meetings. The Competitor will receive the points in the team classification in accordance with the results of the races.

Results of Guest Drivers will not count towards the Team Classification of the Series.

Drivers registered for the whole season classified behind a guest driver in the race results will move up within the points ranking accordingly.

### **8.1.5 Rookie classification**

The Rookie classification is independent of the driver and team rankings.



Points for the Rookie Classification will not be awarded separately but will be based upon the points scored in the Overall Classification.

An additional point is awarded to the driver who achieves the pole position "Rookie" and the best lap in the race.

If a Rookie finished a race behind a non-Rookie driver, he will not move up in the classification for the Rookie class scoring.

All results count for the final Rookie Classification, there are no void results.

The winner of the Rookie Classification is the driver with the highest total number of points of all races.

As a reminder, Rookies drivers are drivers from the "Pro" category. The classification must have at least a minimum of 3 drivers. Otherwise end of season allocations for this ranking will be cancelled.

Porsche Junior drivers are not eligible to enter the Rookie Classification.

## 8.2 Tables of points

Participants who satisfy the conditions for the awarding of points in the driver and/or team ranking shall be allocated the following points in the order in which they are placed in each race, in accordance with the rules for the Driver and/or Team Classification:

1 <sup>st</sup> place	25 points	9 <sup>th</sup> place	7 points
2 <sup>nd</sup> place	20 points	10 <sup>th</sup> place	6 points
3 <sup>rd</sup> place	17 points	11 <sup>th</sup> place	5 points
4 <sup>th</sup> place	14 points	12 <sup>th</sup> place	4 points
5 <sup>th</sup> place	12 points	13 <sup>th</sup> place	3 points
6 <sup>th</sup> place	10 points	14 <sup>th</sup> place	2 points
7 <sup>th</sup> place	9 points	15 <sup>th</sup> place	1 point
8 <sup>th</sup> place	8 points	16 <sup>th</sup> place or below	0 point

- 1 additional point shall be awarded for the pole position in General, "Pro-Am" drivers', "Am" drivers' and Rookies classifications.
- 1 additional point shall be awarded for the fastest lap in General, "Pro-Am" drivers', "Am" drivers' and Rookies classifications.

Guest drivers are not included in the Porsche Carrera Cup France drivers ranking and they are not eligible for any prize money. But the guest drivers may participate in every podium ceremony if applicable.

Drivers registered for the whole season placed behind such guest drivers will move up the ranking accordingly.

A driver may change team and/or vehicle and retain his points in the driver rankings.

## 8.3 Equality of points

If an equal number of points is achieved by more than one driver, the positions in the final classification are based on the highest number of first place results, then second place results and finally the number of pole position from all races of the 2023 Porsche Carrera Cup France. If, after application of this rule, a tie still exists, the decision is made based on the better results of the final race.

If an equal number of points in the Teams' Classification is achieved by more than one Team, the positions in the final classification are based on the highest team score (i.e the points of the two eligible Team scoring cars) in the final race. If a tie still exists, then the highest team score in the penultimate race will be considered, and so on. Should a tie remain after team scores from all races have been considered then the higher placed team will be the team with the highest placed eligible team scoring driver in the final race.

## 8.4 Publication of points

Points classifications will be published by the Series Organiser in an official Team Information communication after the end of each event.

Should an error in any classification require a correction to be made after publication, this can be done by the Series Organiser. Any questions or complaints concerning the Series classifications must be submitted in writing to the Series Organiser and be received within seven days of the first publication of the points or prizes concerned.

The points classifications will be considered final seven days after the end of the last event of the season and, subject only to any ongoing judicial or sporting matters, from that time no further amendments or corrections will be made. In case of any disputes concerning point attributions, these will be decided by the Sporting Committee. Decisions of the Sporting Committee will not be subject to protest or appeal.

## 9. Title, prize money & Trophies

### 9.1 Title Overall Winner

The driver who has scored the highest number of points in the Overall Classification after all respective events of the 2023 Series will be awarded the title:

**"Champion of the 2023 Porsche Carrera Cup France"**

### 9.2 Prize money

The prize money is paid by the Series Organizer exclusively to the Competitors (Teams).

#### 9.2.1 Driver Classification for each race

Prize money will be awarded in respect of each race (for drivers who satisfy all relevant conditions) for classifications positions 1<sup>st</sup> to 7<sup>th</sup> (Overall Classification) of each official race result.

If a substitute driver competes under a registered start number in the 2023 Porsche Carrera Cup France and finishes between 1<sup>st</sup> and 7<sup>th</sup> places on the overall ranking, the driver will be awarded the prizes corresponding to his rank in the race, except for the two last meetings of the season (races 8 - 9 - 10 - 11).

The substitute driver's car entered for the season will score points in the Team classification (See Article 8.1.4).

The guest drivers and teams as well as the one registered under the name "Porsche Carrera Cup France" are excluded from the prize money. Drivers placed behind a guest may therefore move up in the ranking and thus be awarded prize money in accordance with their position in the ranking.

##### 9.2.1.1 Overall classification

1 <sup>st</sup> place	3 500 € ex-VAT	5 <sup>th</sup> place	1 000 € ex-VAT
2 <sup>nd</sup> place	2 500 € ex-VAT	6 <sup>th</sup> place	800 € ex-VAT
3 <sup>rd</sup> place	1 500 € ex-VAT	7 <sup>th</sup> place	500 € ex-VAT
4 <sup>th</sup> place	1 200 € ex-VAT		

Prize money for Le Mans' race will be awarded as follows:

1 <sup>st</sup> place	7 000 € ex-VAT	5 <sup>th</sup> place	2 000 € ex-VAT
2 <sup>nd</sup> place	5 000 € ex-VAT	6 <sup>th</sup> place	1 600 € ex-VAT
3 <sup>rd</sup> place	3 000 € ex-VAT	7 <sup>th</sup> place	1 000 € ex-VAT
4 <sup>th</sup> place	2 400 € ex-VAT		

For foreign teams, a withholding tax of 15% will be levied by Porsche France, in order to comply with French tax legislation.

### 9.2.1.2 Additional Rewards

#### Michelin Allocations

At the end of each race, our exclusive partner Michelin will offer:

- 1 set of tyres "Cup" for the winner of the "Pro" Classification
- 2 tyres "Cup" for the winner of the "Pro-Am" Classification

### 9.2.2 End of season allocations

Prize money will be awarded in respect of the Championship Standings after the last race of the Series (for participants who satisfy all relevant conditions) for classification positions 1 to 3 for all classifications (Overall / Pro-Am / Am / Rookie / Team Classification).

End of season allocations will be awarded as follows:

#### **9.2.2.1 General allocation for "Pro- class drivers"** (Overall Ranking without "Pro-Am" and "Am" class drivers)

1 <sup>st</sup>	45 000 € ex-VAT
2 <sup>nd</sup>	25 000 € ex-VAT
3 <sup>rd</sup>	15 000 € ex-VAT

#### **9.2.2.2 General allocation for "Pro-Am class drivers"**

1 <sup>st</sup>	TBC
2 <sup>nd</sup>	TBC
3 <sup>rd</sup>	A prize provided by a PCCF partner

#### **9.2.2.3 General allocation for "Am class drivers"**

1 <sup>st</sup>	TBC
2 <sup>nd</sup>	A prize provided by a PCCF partner
3 <sup>rd</sup>	A prize provided by a PCCF partner

#### **9.2.2.4 Allocation Teams Ranking**

1 <sup>st</sup>	8 500 € ex-VAT & a prize provided by a PCCF partner
2 <sup>nd</sup>	5 500 € ex-VAT
3 <sup>rd</sup>	3 800 € ex-VAT

#### **9.2.2.5 General allocation for "Rookie drivers"**

The winner of the Rookie Classification will receive a prize at the end of the season. Providing that at least three Rookies enter the classification for the whole season. If this condition is not met the bonus will be cancelled.

If there are not three drivers corresponding to the definition of "Rookie", the allocation will be given to the best driver under 25 years old in the overall ranking.

1 <sup>st</sup>	15 000 € ex-VAT
-----------------	-----------------

### 9.2.3 Payment Allocations

The prizes will be paid exclusively by the Series Organiser to the competitor (Teams) named in the entry form. This is subject to the condition that the competitor does not owe any outstanding amounts to Porsche France and its subsidiaries, that all entry conditions and conditions of participation have been adhered to and no sports disciplinary proceedings are outstanding that could influence the final points count.

The presence at the Prize giving ceremony of the Porsche Carrera Cup France is mandatory for the first three drivers in each category. Unless a valid reason approved by the Organizing Committee, the absence in the awards may cause non-payment of allocations end of the season.

The presence in the Porsche Motorsport Night of Champions at the end of the season for guest drivers is also mandatory. Any unjustified non-presence may result in the event of non-payment of allocations at the end of the season.

In any way, bonuses to pay may offset any debt in connection with the team and its vehicle(s), due to Porsche France or ORECA with no possible contestation from the driver, the team making its case of any contestation from the driver.

## **9.2.4 Prizes in kind**

The Series Organiser may also remunerate the drivers with a prize in kind for their successful participation.

### **9.2.4.1 Special prize for "Fastest laps"**

The driver who has achieved the highest number of fastest race laps in all races will receive a prize by a Porsche Carrera Cup France partner. If two drivers achieve the same number of fastest laps, the prize will be awarded to the driver who has scored the most points in the Overall ranking.

### **9.2.4.2 Trophies**

Trophies will be awarded by the Series Organiser after each race to the 1<sup>st</sup>, 2<sup>nd</sup> and 3<sup>rd</sup> classified drivers of each classification (Overall, Pro-Am, Am and Rookie).

Trophies will also be awarded by the Series Organiser at the end of the season to the 1<sup>st</sup>, 2<sup>nd</sup> and 3<sup>rd</sup> classified drivers of each classification (Overall, Pro-Am, Am and Rookie) and to the 1<sup>st</sup>, 2<sup>nd</sup> and 3<sup>rd</sup> overall classified competitors in the Teams classification.

## **9.2.5 Porsche Motorsport Junior Program**

All drivers under 25 on January 1<sup>st</sup>, 2023 will receive individual coaching from a professional driver designated by the Organizing Committee. The drivers of the Porsche Carrera Cup France will be selected by the Organizing Committee on sporting and behavioural criteria. At the end of the season, the selected young talent will be invited to a test day event organized by Porsche Motorsport (and confirmed by Porsche AG).

The winner of the test day event organized by Porsche Motorsport will receive funding to participate in the Porsche Mobil 1 Supercup.

## **9.2.6 Porsche Carrera Cup France Junior Program**

The winner of the Porsche Carrera Cup France Junior Program will become for the whole season the "Junior Carrera Cup France". The designated driver will receive a reward of 40,000 € ex-VAT to finance his season and a Michelin tires allocation. The evaluation is conducted by a panel chosen by the Porsche Carrera Cup organiser after an evaluation session.

# **10. Private practice and testing**

Private tests are prohibited during the 15 days preceding the start of a meeting on the circuit concerned, with the exception of private tests organised by the Porsche Carrera Cup France.

# **11. Administrative checks**

## **11.1 Administrative checks**

The Competitor and driver must ensure that all the necessary documents as set out in the organiser's rules of participation are submitted by the correct date and time for administrative checks. Failure to comply with this requirement may result in disqualification from the competition. The following documents must be presented by the Competitor/Driver:

- Competitor's Licence
- Driver's licence
- ASN confirmation (if needed)
- Declaration form for cars eligible for the Teams ranking (for teams having more than 2 cars)

- Medical aptitude form
- Authorisation to take part in relevant competitions abroad

The requirement for completion of administrative checks and licence verification applies to the official season Tests and all race events.

In accordance with Article 11.9.4 of the FIA International Sporting Code, the Series Organizer's digital notice board serve as the official medium for announcement.

All competitors, drivers and officials will be given appropriate access details.

Competitors and drivers must respect the schedules of the administrative checks. The schedule of administrative checks will be announced in the Team Information communication of each meeting

Any failure to do so may be reported to the Stewards.

All Competitors and Drivers may be required to submit a signed declaration at each event regarding the validity of their licence and any necessary authority to participate. Where this is required, Competitors will be informed by the Series Organiser and must submit the declaration by the time specified in the Official Timetable for the event.

## **11.2 Driver's briefing**

A mandatory drivers' briefing is held before every free practice.

The time and location of the drivers' briefing will be published in official Team communication before the event and in the Supplementary Regulations of the event. All drivers, together with their Competitor's Team Manager or other authorised representative, must be present throughout the briefing.

The requirement to attend any scheduled drivers' briefing applies to all race events and official season tests. A driver may not take part in a race event or a test session until he has attended the respective drivers' briefing or, where agreed by exception, received a personal briefing from the Race Director.

The Briefing notes and the event specific notes issued by the Race Director are considered formal instructions which must be complied with.

Any non-attendance or late attendance may result in a fine or other penalty being imposed by the stewards.

Any driver operating a mobile device (phone, tablet, etc) during the briefing, other than for the purposes of the briefing, will be deemed to be absent and will be referred to the stewards.

In the event of a driver failing to attend or arriving late, a fine to the amount of at least 300€ ex-VAT, payable to the relevant ASN, shall be due. This fine is to be paid before the start of the meeting.

If a driver misses the briefing, he must present himself directly to the race director in order to receive a personal briefing.

## **11.3 Team Managers' meeting**

The time and location of the Team Managers' meeting is specified in the official Team communication for each meeting. Participation is mandatory. Any non-attendance or late attendance may incur a penalty.

Any instructions issued at the Team Managers' meeting must be complied with.

## **11.4 Official meetings / representation meetings**

The time and place for all official meetings, press conferences and representation meetings (autograph session, photoshoots, etc.) are specified in the internal event schedule.

Any established non-participation or incomplete participation may incur a fine being imposed by the Stewards.

## **12. Scrutineering / Technical checks**

Before and, as required, during or after each competition all cars will be inspected by one or more Technical Scrutineers licenced by the FFSA or any other ASN affiliated with the FIA.

The names of the scrutineers will be stated in the Supplementary Regulations for the event or in a Stewards' bulletin. They may be provided by the promoter or by the Series organiser.

Any car or any part of a car can be selected at any time by the Stewards for a further technical examination, including examination outside the event venue.

The Technical Scrutineers are responsible for the operation of the Parc Fermé and are the only persons authorised to give instructions in this respect to the Competitors.

The Technical Scrutineers are entitled to check any aspects of the cars in competition at any time during the event and may conduct checks without prior request from the Race Director or the Stewards.

Competitors and drivers shall at all times follow the instructions of the Technical Scrutineers regarding the checking and re-inspection of cars.

## **12.1 Initial Scrutineering**

At each competition, the competitor must present his car and the driver must present the compulsory driver's safety equipment at Technical Scrutineering at the published times.

Competitors and drivers must respect the schedules of the scrutineering. If not, a penalty of 110€ (VAT Excl.) will be given for unjustified reason by the Stewards.

Cars, engines and drivers' safety equipment's must to be presented to the Technical Scrutineers in the configuration as it will be used in the competition.

Cars must be presented to scrutineering with the official stickers of the 2023 Porsche Carrera Cup France (Appendix 3). The car must be presented without fuel only for the first event.

It is the Competitor's responsibility to ensure that the car fully complies with the applicable technical regulations at all times during the competition, starting with the technical scrutineering prior to the competition.

The presentation of a car for technical scrutineering will be considered as an implicit declaration of conformity.

The following documents must be presented with the car to the Technical Scrutineers:

- Technical passport
- Certificate for rollover structure
- Fuel Tank certificate

Once initial technical scrutineering is completed, the cars may only leave the paddock during the event with the permission of the Series Organiser. Any car that is permitted to leave the paddock (other than to go on track) must be presented again to the Technical Scrutineers before taking any further part in the competition. It is the Competitor's responsibility to present the car to the Technical Scrutineers.

No car may take part in the competition until it has successfully passed initial scrutineering checks.

Unless a waiver is granted by the Stewards, Competitors who do not keep to the set time limits will not be permitted to take part in a competition.

For equipment checks, each driver must complete and sign the equipment declaration form (helmet, overall, gloves, underwear, shoes, HANS system...), as supplied by the Series Organiser. A declaration of equipment per meeting will be required.

## **12.2 During the meeting:**

After qualifying and each race, the cars must be brought to the Parc Fermé area by the route described in the Drivers' Briefing. The Parc Fermé area of the Series will be identified in the Supplementary Regulations for each event or in the

notes from the Drivers' Briefing. In the absence of any stipulations to the contrary, the "Parc Fermé" is in the Porsche Carrera Cup France paddock. The route from the finish line to the Parc Fermé is subject to the Parc Fermé conditions. Only the driver (in full racing equipment) of the relevant car or one member of the organisation are allowed to drive the car to the Parc Fermé except in exceptional cases ordered by the Series organiser.

All cars are subject to Parc Fermé conditions until the end of the protest period and until released by the Technical Scrutineers or the Stewards. During this time, no works of any kind may be performed on the cars. Once in the designated area, no car may be removed without the permission of the Technical Scrutineer / Stewards. No individual may enter Parc Fermé without the permission of the Technical Scrutineers.

Cars that have been involved in an accident at any time during the event must be presented to the Technical Scrutineers. Any repairs identified by the Technical Scrutineers must be undertaken by the competitor and the car represented to the Technical Scrutineers. It is the competitor's responsibility to do so before taking part in the competition again. Changing an engine or a gearbox must be approved by the organiser in written form prior to the change.

The stewards or the Race Director can require a driver to have a medical examination at any time during an event. Any failure to comply may result in disqualification from the competition.

Any car that is permitted to leave the paddock for repairs after an incident must be presented again to the Technical Scrutineers before taking any further part in the competition. It is the competitor's responsibility to present the car to the Technical Scrutineers.

It is not permitted to drive the competition cars on public roads at any time during an event, unless specifically defined in the Drivers' Briefing.

The stewards will publish the results for each car scrutineered. These results will not include any specific figures or data except where a car is found to be in breach of the technical regulations.

Only car's team members are allowed during the technical scrutineering, no one else is allowed in the area.

## **13. Running of the competitions**

The events will be run according to the FIA General Regulations for Events held at circuits, unless specified otherwise in the rules and regulations of the respective promoters.

### **13.1 Pre-Start**

The pre-start is the line-up of all cars before entering the circuit for the free practice, qualifying and races.

The pre-start begins as soon as the car leaves their team awning and ends when the car enters the pitlane.

All cars must be driven from the team awning/pit to the official pre-start by the relevant driver. Any authorised exceptions will be announced by the Series organiser at the beginning of the event. All drivers must be ready in full racing equipment in their team awning/pit at the time defined in the schedule.

Should a competitor or driver not be ready in time he may forgo the right to take part in the relevant session. The final decision on participation in the session is taken by the Stewards.

If a competitor or a driver does not wish to go the pre-grid when the instruction is given, then he will only be able to join it after the last competitor has called. He will not be able to return to his initial position before the pre-grid opens.

During the pre-start, no modifications must be made to the car, unless otherwise indicated by the race direction, except:

- Switching on the on-board cameras
- Installation of the sun visor
- Tire pressures can be adjusted using a manometer only

## 13.2 Free Practice

Two free practice sessions of 40 minutes (without exceeding 60 minutes) will be scheduled for each competition (Except Le Mans) (after validation of the Promoter and the local ASN).

When team awnings are used, the cars will be placed in a specific order to get to the pre-start.

For the first pre-start of the season, the order of the cars will be determined by their starting number. Smallest number will start first, second smallest will start second and so on (the lowest number being 1). Guest starters will be placed at the end by their starting number.

For the following sessions, the order will be determined by the results of the previous sessions. The result of race 2 will determine the order of the pre-grid for free practice 1 of the following meeting. (Except Le Mans)

Any drivers who were not classified in the previous race, will then be placed in the pre-start in the following order:

- Any driver who participated in the previous race but was not classified.
- Any Guest driver

In each of the above cases, the drivers will be placed in the order of their race number. Any driver who participated in the preceding race but using a different race number will, for these purposes, be considered not to have participated.

Any car unable to leave the pre-start area and enter the track with the rest of the cars will be given a further minute (60 seconds) to leave the pre-start area and proceed to the pit lane. After this time, any car which has not left the pre-start will only be permitted to proceed to the pit lane at the sole discretion of the Race Director.

The free practice session time duration may be reduced in length should it be temporarily stopped for reasons of safety or force majeure.

Should a practice session be stopped for any reason, all cars must return slowly back to the pit lane, without overtaking the other cars.

If two or more cars set identical fastest lap times in practice, the classification order will be based on the order in which those times were set, with the first car to set that time taking precedence, and so on.

During any practice session any driver who, in the opinion of the Stewards, stops or slows unnecessarily on the circuit or impedes another driver may receive a penalty. Any driver causing a practice session to be stopped may be referred to the Stewards and may receive a penalty.

If the number of competitors/drivers entered exceeds the number of competitors authorised by the regulations of the event, the Series organiser will decide, in agreement with the Stewards', on the terms and conditions of admission to free practice and qualifications for the respective event.

## 13.3 Qualifying

One qualifying session will be held at each competition (except Le Mans), with a total duration of 30 minutes.

Each driver's best time will determine their position in Race 1, their second-best time will determine their position in Race 2. Admission to the races and to the starting grid will depend on the final results of the qualifying session. All participants must qualify for each race.

The order of the cars in the pre-start for qualifying is defined by the results of the free practice 2 of the respective competition.

In case of cancellation of Free Practice 2 due to exceptional circumstances, the order of the cars for the qualifying session will be defined by the results of Free Practice 1 (Guest drivers will be placed at the back in the order of their race numbers).



Should unforeseen circumstances force the cancellation of the free practice session 1 & 2, the pre-start order of the cars for qualifying session will be defined by the results of the preceding race. For the first meeting of the season, the order will be defined by draw and Guest drivers will be placed at the back in the order of their race numbers.

Any car unable to leave the pre-start area and enter the track with the rest of the cars will be given a further minute (60 seconds) to leave the pre-start area and proceed to the pit lane. After this time, any car which has not left the pre-start will only be permitted to proceed to the pit lane at the sole discretion of the Race Director.

A driver will be admitted to a race by participating in the qualifying session and achieving a qualifying time not exceeding 107% of the fastest driver in the qualifying session.

No driver may take the start of a race without having taken part in the qualifying or practice session, unless authorised by the Stewards in consultation with the race director.

Any driver failing to meet the qualifying criteria and wishing to participate in the race must make written application to the Stewards of the event. Admission of drivers who have not qualified will be considered by the Stewards in consultation with the Race Director.

If a driver is unable to set a meaningful lap time in Qualifying, one factor which may be considered is whether the driver set a suitable lap time in the Free Practice sessions.

However, neither the Stewards of the event nor the Race Director are under any obligation to accept any application from any driver who has not met the qualifying criteria and their decision in this respect is not subject to protest or appeal.

The "normal" qualification format for the 2023 season is the following:

**Format:**

One qualifying session:

30 minutes for all drivers to determine the starting grid of the race 1 and for the race 2.

The best time achieved during this session will determine the position on the starting grid for the race 1, the second-best time of this session will determine the position of the starting grid for the race 2.

If two or more cars set identical fastest lap times in qualifying, the classification order will be based on the order in which those times were set, with the first car to set that time taking precedence, and so on.

We also remind you that during each qualifying session (of each driver), general permitted modifications can be done on the car, excepted front ride height change.

At the end of the qualifying session, all cars which participated in the session are subject to the Parc Fermé rules (place announced during the drivers briefing).

The cars chosen by the scrutineers have to go directly to the scrutineering area. The scrutineering area used for is located under the awning of the Series Organiser.

All intervention on the car in the Parc Fermé after the qualifying sessions and the races is prohibited, including control of tyre pressure/temperature.

In case of accident/incident, the entrant has to be allowed by the Porsche Carrera Cup France technical manager or scrutineer before repairing the damage.

No change in the maximum number of competitors authorized by the approval of the circuit concerned is possible.

**Session interruption:**

If the Race Director decides to stop the qualifying session prematurely for any reason, all cars must return slowly back to the pit lane, without overtaking the other cars. The restart of the qualifying session as well as the remaining time will be indicated on the screens in the pits.

If a qualifying session is suspended (red flag) and subsequently resumed, then teams are allowed to work on their cars. However, if a qualifying session is stopped and is not continued then all work must stop, and all cars will be under Parc Fermé conditions from the moment when it is declared that the session will not be resumed.

Should circumstances force the cancellation of the entire qualifying session, then the times set in the free practice sessions will be used to determine the starting grids. The best free practice time of the driver in question determines his position on the starting grid for race 1, while the second-best free practice time of the driver in question determines his position on the starting grid for race 2. All free practices times (lap without penalty) of the event will be combined for this calculation.

Should the qualification session be stopped and cannot be resumed, the following will apply:

- If less than 7 minutes have been completed the session will be deemed null and void and the times set in the free practice sessions will be used to determine the starting grid (including as above for competitions with 2 races).
- If 7 minutes or more have been completed the qualifying session classification will be used to set the starting grids.

For the starting grid of race 1, any driver who has not set a lap time in qualifying will be placed behind those cars which have done so, in the order based on their fastest free practice time.

The starting grid for race 2 will be determined by each driver's second fastest time set in qualifying and any driver who has not set a second lap time in qualifying will be placed behind those cars which have done so, in the order based on their fastest free practice time.

Should circumstances force the cancellation of both the free practice session and the qualifying session, then the current championship positions at the beginning of the event will be used to determine the starting grids of the two races. Any drivers with a null score will be placed in the order of their competition number behind those with a score, and any Guest drivers will be placed behind them in the order of their competition number.

For the first event of the season, the order of the cars will be determined by a draw, Guest drivers will be placed at the back in the order of their competition numbers.

During any qualifying session any driver who, in the opinion of the Stewards, stops or slows unnecessarily on the circuit or impedes another driver may receive a penalty. Any driver causing a qualifying session to be stopped may be referred to the stewards and may receive a penalty.

### **13.4 Starting grid**

The starting grid for the race 1 will be determined by the fastest times achieved during the qualifying session as defined in Article 13.3 and will be formally signed by the Stewards and by the race director. Should any grid place penalties be applicable, these will be applied in the order in which the relevant offences occurred.

The driver with the fastest qualifying time takes up the race from the first place on the grid. He will be followed by the driver with the second fastest time, etc.

The starting grid for race 2 will be determined by the second fastest time of each driver achieved during the qualifying session.

If one or more drivers have not set a lap time (for reasons other than cancellation or shortening of the qualifying session), but are given permission by the Stewards to take part in the race, these drivers will be placed at the end of the starting grid in the following order:

- a) The drivers who have started a timed lap from the pit lane, in the order of their best time in free practice.
- b) The drivers who have not started a timed lap from the pit lane, in the order of their best time in free practice.

Drivers whose lap times were cancelled by decision of the Race Director or the Stewards must in all cases start the race behind the aforementioned drivers at the end of the starting grid. Should more than one driver have his/her entire times removed, their standing positions at the back of the grid will be determined by their best time in free practice.

Should the Stewards be required to settle any matter in relation to the starting grid order for any race (or the pre-start order for any practice or qualifying session), their decision in this respect will not be subject to appeal.

The change of tyres on the grid is not allowed whereas it is allowed on the pre-grid only when cars are installed in the box, except if another instruction is given by the race director.

The route from the pre-start to the starting grid will be explained in the Drivers' Briefing and must be followed. Driving one or more laps and through the pit lane is not permitted unless specifically ordered by the Race Director. The order of the cars in the pre-start is determined by the result of the qualifying sessions.

On the starting grid, only tire pressures can be adjusted using a manometer only.

Should unforeseen circumstances force the cancellation of the 1<sup>st</sup> scheduled race then the 2<sup>nd</sup> scheduled race will be run with the grid times set for race 2.

### **13.5 Starting modes**

All races will be a standing start (except Le Mans) staggered formation (GP start) unless amended by instruction of the race director.

### **13.6 Races**

The 2023 Porsche Carrera Cup France will consist of :

- 5 meetings of 2 races (30 minutes per race) with a standing start.
- 1 meeting of 1 race (45 minutes) with a rolling start

If a race is cancelled because of force majeure or for safety reasons, the Series Organiser reserves the right to reduce the number of races in the Series or to organize a new race, including on another meeting of the calendar (which could lead to 3 races on the same meeting). The Series Organiser is under no obligation to reschedule a race in its original format within an event.

### **13.7 Starting Procedure**

The "normal" start will be a standing start, engine turned on, as described in the article 8.4 of the ISC.

In some case, a lighter starting procedure could be used (in terms of article 7.3.1.4.2. of Standard Regulations for Asphalt Tracks) if asked by the organiser. It has to be written and approved by the Series before the start of the event.

The order of the cars in the pre-start is determined by the result of the relevant qualifying session. Cars will be driven from the pre-start area to the starting grid using the route described in the drivers' and Team Managers' briefing.

Competitors must not place any tape or other forms of marking on the pit wall in order to indicate grid positions to drivers. Cars must be positioned within their respective grid space marking, with no part of the contact patch of the front tyres ahead of, or outside of, the white line marking the front of the space. No tyre may be wholly beyond the white lines defining the side of the grid space.

Any car unable to leave the pre-start area and enter the track with the rest of the cars will be given a further minute (60 seconds) to leave the pre-start area and proceed to the grid. After this time, any car which has not left the pre-start will not be permitted to take up its position on the grid and must start from the pitlane if able to do so and if track access routes allow.

At circuits where cars are instructed to go directly from the pre-start area to their respective starting positions on the grid, any car which instead enters the pitlane must start the race from the pitlane.

Such cars may join the race when the pitlane exit light is turned to green once all cars on the grid have started the race and have passed the pitlane exit.

At circuits where the cars are instructed to enter the pitlane then complete one full lap before taking up their starting positions on the grid, a 'pitlane open' and 'pit lane closed' time will be given. This is the window when the pit exit will be open for cars to leave the pitlane to go to the grid. When cars are instructed to enter the pitlane from the pre-start area, they may line up in the fast lane to await the 'pitlane open' time or may go to their pit area, but all must leave the pitlane before the pit exit is closed. Any car which has not left the pitlane at the 'pitlane closed' time may start the race from the pitlane if able to do so. Any car which re-enters the pitlane when approaching the grid must start the race from the pitlane. Such cars may join the race when the pitlane exit light is turned to green once all cars on the grid have started the race and have passed the pitlane exit.

Any car that leaves the pre-start but stops before arriving on the grid and is unable to continue under its own power will be removed to a place of safety. At the sole discretion of the Race Director it may be recovered to the pitlane. If the car is subsequently able to start the race, it may do so from the pitlane. Such cars may join the race when the pitlane exit light is turned to green once all cars on the grid have started the race and have passed the pitlane exit.

It is permitted for teams to use sun visor whilst on the grid, to cool the car and the driver. All such devices must be removed by the time of the 3-minute signal.

On display of the 3-minute signal and/or any audible signal, all competition cars must be standing on their wheels on the track and must not be lifted again.

On display of the 1-minute signal and/or audible signal, all personnel must clear the grid.

At the end of the count down, all cars on the starting grid will begin the Formation Lap. Cars in the pitlane are not permitted to participate in the Formation Lap. There will be one Formation Lap prior to each race unless, under exceptional circumstances, the Race Director instructs two or more Formation Laps.

If a car cannot start the Formation Lap, the driver must make himself known to the starter by means such as flashing the head lights, waving his arm, etc. If the driver can restart the car and leaves the starting grid under his own power before he has been overtaken by the last competing car, then the driver must not overtake any cars but must maintain position during the Formation Lap. At the end of the Formation Lap, the driver may resume his original starting position on the grid.

If the car is restarted under its own power, or is pushed by marshals, and then joins the Formation Lap after the last car has passed, then the driver must remain at the back of the starting field and take up the last starting position on the starting grid. The vacant space on the grid must not be made up by other cars.

If a car cannot start under its own power or with the assistance of the marshals, then it will be pushed into the pitlane by the marshals. If the driver can restart the car, then he must wait in the pitlane until the race has started and may join the race when the pit exit light is turned to green once all cars on the grid have started the race and have passed the pitlane exit.

At the end of the Formation Lap, all cars shall promptly take up their grid positions. Once stopped in their grid positions, cars must not move until the race start signal is given.

- The side of the pole position will be defined by the homologation of the circuit.
- The Starter will use the Formula 1 light sequence to start the race.
- Should a driver be in an incorrect position on the grid or move forward from his grid position before the race start signal is given (red lights out), this may be recorded as a 'False Start' and be referred to the Stewards. The Race Director and/or Stewards may use any video or electronic means to assist them in reaching a decision regarding false starts.

If a driver has a problem on the grid after the Formation Lap then he must make this known to the starter by means such as flashing the head light, waving his arm, etc. If the Starter decides to delay the start, the yellow flashing lights will be switched on. Then the green lights will be illuminated, and drivers must complete a further Formation Lap. The driver that caused the Delayed Start will be pushed into the pitlane and will, if able, he will start the race from the pitlane. The race distance/time will be reduced each time this occurs.

In case of an additional Formation Lap (incident on the track or other case) the race director will announce his decision concerning the timing of the end of the race.

### **13.8 Aborting or suspending a race**

After the signal to stop the race has been given, all cars able to do so will proceed directly but slowly to the grid or to another position on the track as directed by the Race Director.

If a race is aborted or stopped before the leading car has finished 2 complete racing laps, the following rules will apply:

- The start will be declared a "No Contest", however penalties may be imposed for any breaches of the regulations during the aborted/stopped race and at the discretion of the Stewards, these may be applied to the restarted race.
- If all cars are directed to the grid, cars may be worked on only if they enter the pitlane or are already in the pitlane at the time of the red flag. Any car already in the pitlane or entering the pitlane after the red flag may start the race from the pit lane after all cars have started the race.
- If all cars are directed into the pitlane when the red flag is shown, they must line up in the Fastlane. Cars may only be worked on if they go to their own pit area. Any car which goes to its own pit area will be permitted to start the race from the pitlane when the pit exit light is turned to green after all cars which remain in the Fastlane have started the race and have passed the pitlane exit.
- Retired competitors unable to take part in the restart of the race in their original car will be classified as non-starters.
- All drivers having taken the original start shall be eligible for the restart in their original car.
- The length of the restarted race will be defined by the Race Director in consultation with the Stewards.
- The grid for the restart will be the original starting grid.
- Empty starting places on the starting grid, caused by drivers unable to restart or starting from the pitlane, will not be filled. Empty starting rows will be filled by moving up.
- Refuelling is prohibited.
- The Race Director may decide that the restart will take place behind the Safety Car for operational or safety reasons, in which case this may commence from the pit lane if all cars were directed there.

If a race is aborted or suspended after the leading car has finished two complete racing laps, the race shall be deemed to be in two parts, the first of which finished when the leading car crossed the control (timing) line for the penultimate time before the red flag was shown.

- The length of the second part will be the original race distance less the number of minutes done by the leader before the red flag was shown.
- The grid for the second part will be a standard grid with the cars arranged in the order in which they finished the first part. Gaps on the grid will be made up.
- The Race Director may decide that the second part of the race will start behind the Safety Car for operational or safety reasons, in which case this may commence from the pitlane if all cars were directed there.
- The countdown for the start of the second part will commence with the 5-minute signal unless the Race

Director decides otherwise.

- Only cars which took part in the first start will be eligible and then only if they returned to the grid or pitlane under their own power by an authorized route.
- No spare cars or reserves will be eligible.
- Refuelling will not be permitted.
- If all cars are directed to the grid, cars may be worked on only if they enter the pitlane or are already in the pitlane at the time of the red flag. Any car already in the pitlane or entering the pitlane after the red flag may start the race from the pitlane when the pit exit lights is turned to green after all cars on the grid have started the race and have passed the pitlane exit.
- If all cars are directed into the pitlane when the red flag is shown, they must line up in the fast lane. No intervention on the cars is allowed unless they go to their own technical area in the working lane. Any car which goes to its own pit area will be permitted to start the second part of the race from the pitlane when the pit exit lights is turned to green after all cars which remained in the fast lane have started the race and have passed the pitlane exit.
- The classification of the race will be the order of finishing of the second part.

If a race is aborted or suspended after the leader has completed more than 50% of the scheduled racing time then, at the Race Director's sole discretion the race may not be restarted.

If a race is stopped before the time of the race has been achieved and the race is not restarted, then the results will be declared on the basis of the classification order when the leading car crossed the control (timing) line for the penultimate time before the race was stopped.

Any driver causing a race to be stopped may be reported to the Stewards and may be subject to penalty up to disqualification from the race.

### **13.9 Change of weather conditions**

For all sessions, teams and drivers are free to choose slick tyres or wet-weather tyres at any time.

At the start of a race, once the cars have left the Team area and taken position in the pre-start, the pit crew equipment and tyre trolleys will go from the paddock into the pit lane.

If there is a change in weather conditions prior to the start of a race, the following may apply:

a. During the pre-start procedure

- The Race Director will confirm where tyres may be changed and the procedure for doing so.
- The normal start procedure will then begin from the 5-minute signal. If the weather conditions continue the Race Director may elect to start the race behind the Safety Car.

b. During the start process (on the grid) before the formation lap

- The drivers will be shown the "Start Delayed" board.
- The Race Director will decide where teams may change tyres and issue instructions accordingly.
- The normal start procedure will then begin from the 5-minute signal. If the weather conditions continue the Race Director may elect to start the race behind the Safety Car.

c. During the Formation Lap

- The start will be aborted.
- The Race Director will decide where teams may change tyres and issue instructions accordingly.
- The normal start procedure will then begin from the 5-minute signal. If the weather conditions continue the Race Director may elect to start the race behind the Safety Car.

If the start or re-start of the race is made behind the Safety Car due to the weather conditions, then the use of wet-weather tyres is compulsory until the Safety Car has returned to the Pits. The start or re-start may be from the pitlane.

A race will not be stopped in the event of rain unless the circuit is blocked, or the Race Director considers it unsafe to continue.

### **13.10 False start**

The Race Director and/or Stewards may use any video or electronic means to assist them in reaching a decision regarding false starts.

### **13.11 Safety Car**

The Safety Car will be deployed under the instruction of the Race Director to neutralise a race. This will be deployed in accordance with Article 2.10 of Appendix H to the FIA International Sporting Code.

For the first lap of each race the Safety Car will be positioned before the last corner. If the start/finish straight is completely blocked, drivers will have to follow the Safety Car through the pitlane (fast lane).

The Safety Car procedure will be that firstly, waved yellow flags with stationary 'SC' boards will be displayed around the circuit. All cars must slow down immediately – overtaking is prohibited. The Safety Car will then be deployed to pick up the leader and all cars must remain no more than 5 car lengths apart.

Once the Race Director is satisfied that racing may resume, the Safety Car lights will normally be switched off at the timing line Sector 2 (refer to the event circuit map) and all "SC" boards will be withdrawn but yellow flags will continue to be displayed.

As the Safety Car enters the pit lane, a green flag will be displayed at the control (timing) line, to signify the resumption of the race and at this time all yellow flags will be withdrawn. Should the Safety Car enter the pit lane during the last race lap of the race then the yellow flags will continue to be displayed at the marshals' posts.

A driver is not permitted to overtake another car until his car has reached the control (timing) line.

### **13.12 Finish**

The end-of-race signal will be given at the control line as soon as the leading car has covered the full scheduled race time or has covered the greatest distance within the scheduled race time.

Should for any reason (other than when a race is aborted or suspended in accordance with Article 13.8) the end-of-race signal be given before the leading car completes the scheduled number of laps, or before the prescribed time has been completed, the race will be deemed to have finished when the leading car last crossed the Control Line before the signal was given. Should the end-of-race signal be delayed for any reason, the race will be deemed to have finished when it should have finished.

After receiving the end-of-race signal all cars must proceed on the Circuit directly to the Parc Fermé without stopping and without any assistance (except that of the marshals, if necessary), except the cars of the top 3 of each classification (Overall / Pro-Am / Am) which will go to the podium area.

Any classified car which cannot reach the Parc Fermé under its own power will be placed under the exclusive control of the marshals who will take the car to the Parc Fermé.

The control (timing) line applies both to the track and to the pit lane, except for the end of the race where a driver must take the chequered flag on the track in order to be classified for that lap.

## 14. Protests and Appeals

Protests and appeals must be made in the legal and procedural framework of the FIA International Sporting Code. All requests for claims relating to the sport are to communicate directly to the Clerc of the course.

In accordance with Article 12.3.4 of the FIA International Sporting Code, certain decisions are not subject to appeal. No appeal may be made against any element of decisions resulting in the application of the following penalties applied by the Stewards or the Race Director:

- "Drive-through" or "Stop-and-Go" penalties including those imposed during the last laps of a race (or after the race) and converted to a time penalty.
- Penalties stating or implying the cancellation of a number of practice or qualifying lap times.
- Penalties stating or implying a drop of grid positions for the race.
- Time penalties added to the Driver's elapsed race time (either during or after the race)
- Imposition of Reprimands or penalty points.
- Obligation for a Driver to start a race from the pit lane.

In addition, should the Stewards be required to settle any matter in relation to the starting grid order for any race (or the pre-start order for any practice or qualifying session), their decision in this respect will not be subject to appeal.

Should a "Notice of Intention to Appeal" be submitted to the Stewards, Competitors should note the provisions of Article 15.5.2 of the FIA International Sporting Code regarding the immediate liability for payment of the Appeal deposit, even where the declared intention is not subsequently followed up.

## 15. Acceptance of the Rules

By signing the "Entry Form" each team and driver participating in the Porsche Carrera Cup France acknowledges these regulations and the FIA International Sporting Code with the attachments, as well as the rules of participation of the respective promoters.

If required during the season, the 2023 Porsche Carrera Cup France rules and regulations may be amended, after obtaining authorization from the FFSA and the FIA. Such amendments are to be provided in writing, for example in the form of a "Team Info".

## 16. Television Rights / Advertising

Participation in the Porsche Carrera Cup France 2023 leads to the assignment of all copyrights and image rights of teams and drivers in favour of Porsche France. This includes all images, videos and sounds from the Porsche Carrera Cup France that is made for the TV broadcast, press, Internet and social medias worldwide.

All television rights for the Porsche Carrera Cup France 2023 both terrestrial broadcasting and cable and satellite television, all videos and all rights of exploitation by any electronic media, including the Internet, belong to the Porsche France. All kinds of recording, broadcasting, repetition and reproduction for commercial purposes are prohibited without written permission of Porsche France and can lead to high claims for compensation.

The Series Organiser is entitled to use exclusively all rights of the Competitors, Teams and their Drivers, particularly names, logos, team equipment and cars, for the production of interactive games of the Series and to assign the rights to a third party for this purpose.

## 17. Specific Regulations

### 17.1 Porsche Carrera Cup France Paddock

The public image of the Porsche Carrera Cup France is primordial.



The image of the Series and the participating Teams must always be to a professional standard. This includes, for example, team clothing, articulated lorries, awnings, pit walls and antistatic floor coverings (explicitly no carpet flooring).

All the teams of the Porsche Carrera Cup France without exception will be all together in a single area of the paddock or in the garages, depending on the choice of the organiser, no exceptions will be accepted.

Each team is required to have an articulated lorry with a working awning in accordance with the FIA standard (width: max 8m / Length: 16.50m maximum / trailer including the towing vehicle).

At least two competition cars must be accommodated in each working awning. Particular attention must be paid to the set-up requirements (for example: the floor must be covered - plastic floor covering).

In exceptional cases, the Series Organiser reserves the right to permit the length of the awning to include the length of the tractor unit as well. This needs to be considered when planning for the awnings.

Teams must also provide appropriate means of ensuring that awnings are secured robustly against weather/wind conditions and ensure these are maintained throughout each event.

During set-up and dismantling, each competitor must ensure that all safety aspects of his team working processes are fulfilled and observed.

Should a Competitor have an exceptional need to bring an additional truck to an event, they must seek prior approval from the Series Organiser. Such approval will be subject to paddock space capacity.

Besides, when the operator put some garages to the team attention, the order and places of the cars in the garages are set by the Series Organizer. The teams accept this organisation in advance.

Only the team trucks shall have access to the Porsche Carrera Cup France paddock. Small trucks and trailers shall only have access to the Series paddock for the purposes of loading and unloading during the official set-up and dismantling periods. Tailgates on transporters must remain closed at all times except when loading and/or unloading at the beginning and end of each event.

Passenger cars, motorhomes and other vehicles are strictly forbidden and shall not have access to the Series paddock at any time.

All trucks must be washed and cleaned before they are parked in the paddock. The use of trucks and trailer roofs as well as lifting platforms as spectator platforms is prohibited.

The speed limit in the paddock at each venue is 10 kph.

Timetables for setting up and dismantling will be determined by the Series Organiser for each event and will be communicated in writing at the latest 24 hours before the start of the event in the form of the "Team Infos".

Schedules for the set-up and dismantling periods must be strictly observed.

With the exception of the Porsche Carrera Cup France hospitality, all other kinds of catering are prohibited in the paddock of the Series, unless the organiser has given his approval.

Instructions from the organiser and supervisor of the paddock must be followed at all times.

Teams may use their trailers, including the roof, for advertising, respecting at all times the requirements of Article 1.9 of the Technical Regulations. The Series Organiser retains the right, at its sole discretion, to instruct the removal of any advertising or branding that is deemed offensive or inappropriate.

## **17.2 Pitlane allocation**

Teams will be allocated a working area in the pitlane, different for each event. This pit allocation will be established by the Series Organiser. The teams accept in advance the defined organisation. The organiser shall ensure that the positions of the competitors in the pitlane are fairly distributed throughout the season.

Positions of the cars in pitlane (working lane) will be given by the race director during the drivers briefing.

## **17.3 Instructions of the Series Organiser and Officials**

Instructions of the Series Organiser, their personnel and nominated event Officials must be followed at all times. In the event of failure of any Competitor, Team, Team member, Driver, guest or other individual to comply with these regulations, the Series Organiser will notify the Stewards who may impose a penalty including a fine of at least EUR 500 ex-VAT and up to disqualification from the competition.

## **17.4 Publication obligation**

The nationality of the issuing licence authority of the driver must be stated for publications and podium ceremonies.

## **17.5 Podium ceremony & Award Ceremony**

During the entire podium ceremony, except for the time during which the national anthem is played, the drivers on the podium must wear the caps of the tyre manufacturer on their heads with the logo at the front. No political or otherwise inappropriate statements, signals, gestures or stances may be given or displayed by drivers either leading up to or during the podium ceremony.

The ceremony starts with ascending the podium and ends with leaving the podium after the group pictures for the press. Only drivers and team members are allowed on the podium.

Any violation of this rule will be penalized with a financial penalty of at least 2 500€ ex-VAT by the Stewards payable to Porsche France. The payment of the penalty does not exclude any other additional sanction.

After each race, four podiums ceremony will be celebrated on the main podium in the following order:

- Overall classification of the race
- Pro-Am classification of the race
- Am classification of the race
- Rookie classification of the race

Competitors must nominate a Team member in respect of each of their cars who will return that car from the pitlane to Parc Fermé should its driver be required to participate in any podium ceremony. The names of the Team members nominated for each car must be notified to the Series Organiser during the administrative checks.

Competitors are reminded that these cars remain under Parc Fermé conditions throughout this exercise.

A Porsche Carrera Cup France specific podium could be done in the hospitality after the race.

It is mandatory for the top three drivers in each category to attend the end of season Porsche Carrera Cup France awards ceremony. Drivers who are invited to the "Porsche Motorsport Night of Champions" at the end of each season, are required to attend. Any breach of these requirements may result in the non-payment of premiums at the end of the season unless explicit agreement has been given for their absence. Such agreement will only be given in exceptional circumstances.

## **17.6 Stewards' Inquiries**

The Stewards may hold inquiries into incidents observed by them or referred by the Race Director, Technical Scrutineers, Series Organiser or other parties. The Stewards may seek evidence from any source they choose – in the case of incidents on track the Race Director shall present any video evidence available and at any time requested by the Stewards, including during inquiries with Competitors and Drivers. Drivers attending Stewards' inquiries must always be accompanied by an authorized representative of the relevant Competitor.

## 17.7 Incidents

The Race Director may report any on-track incident or suspected breach of these Sporting Regulations or the FIA International Sporting Code (an "Incident") to the Stewards. After review it shall be at the discretion of the Stewards to decide whether or not to proceed with an investigation. The Stewards may also investigate an incident noted by themselves.

Any incidents involving more than one car may be investigated immediately or reviewed after the relevant session or race.

"Incident" means any occurrence or series of occurrences involving one or more drivers, or any action by any driver, which can be reported to the stewards by the Race Director (or directly noted by the stewards) which:

- Necessitated the suspension of a session (red flag)
- Constituted a breach of these Sporting Regulations or the Sporting Code.
- Caused a false start in a race by one or more cars.
- Caused a collision.
- Forced a driver off the track.
- Illegitimately prevented a legitimate overtaking manoeuvre by a driver.
- Illegitimately impeded another driver during overtaking.

It shall be at the discretion of the Stewards to decide, if any driver involved in an incident should be penalised.

If an incident is under investigation by the Stewards a message informing all Competitors which Driver or Drivers are involved will be displayed on the timing monitors (if the facilities at the circuit so permit). However, failure to display notification that an incident has been placed under investigation will not invalidate that investigation or any subsequent decision and/or penalty.

If a driver is involved in an incident, he must not leave the circuit without the consent of the Stewards.

## 17.8 Penalties

At the individual events, the Stewards of the meeting are responsible for imposing any penalties on the participants (competitors, drivers...) in respect of any breach of regulations. Any case not provided for in the regulations will be studied by the Stewards who alone have the power to make decisions, in accordance with the FFSA regulations and with Article 11.9 of the FIA International Sporting Code.

In addition to the cases listed in the International Sporting Code, these Regulations and the FFSA Regulations, the following circumstances or offences may also incur penalties up to refusal of permission to participate, or disqualification of a participant from the competition:

- Non-compliance with the prerequisites for participation,
- Non-compliance with the Regulations in the Code,
- Advertising for brands that compete with the Series sponsors,
- Unsporting behaviour,
- Failure to comply with the instructions of the Series Organiser,
- Refusal to undergo a car check that has been ordered.

If any special examinations or investigations are required and ultimately lead to a determination of non-compliance with the regulations and/or a penalty being imposed by the Stewards, then the costs of such examinations or investigations shall be met by the Competitor whose car is determined to be non-compliant and/or who is subject to such penalty.

The fact that penalties have been imposed by the Stewards does not rule out more extensive penalties being imposed by the relevant ASN of the FIA. These disciplinary bodies shall also be entitled to disallow points won in races in the 2023 Porsche Carrera Cup France competitions.

Should any Competitor or Driver have points disallowed, no other Competitor's or Driver's score shall be adjusted as a consequence.

In the case of disqualification from a competition, the points gained and the prize money for the relevant race(s) shall be forfeited. In the event of disqualification from participating further in the Series, all points and prize money won up to that point shall be forfeited (no other competitor or driver's score will be adjusted accordingly).

Furthermore, depending on the seriousness of the fault, the Organising Committee of the Porsche Carrera Cup France reserves the right not to accept the driver commitments in the following events.

The Stewards may impose any penalty they consider appropriate for a breach of the regulations, up to disqualification from the competition. The Stewards may also decide to impose a suspension for one or more competitions of the Series. Appendix 8 contains a set of guideline penalties that will be taken into consideration by the Stewards, but each will be considered on its own merits.

If a driver is sanctioned with a time penalty during a session (Free Practice 1 and Free Practice 2) and he can't do this penalty before the end of this session, the penalty will be carried over to the following session. The driver will have to do this penalty at the beginning of the next session.

Should the Stewards decide to impose either a "Drive-Through" or a "Stop-and-Go" penalty, the following procedure will be followed:

- The Stewards will give notification of the penalty which has been imposed to the Competitor concerned by means of a message on the timing monitors. The Race Director will also announce the penalty through the radio system.

It is the responsibility of the team manager of the driver to announce the penalty to his driver.

- From the time the Stewards' decision is notified on the timing monitors the relevant driver may cross the control (timing) line on the track no more than twice before entering the pitlane. In the case of a "Drive-Through" penalty the driver must proceed down the pitlane and re-join the race without stopping. In the case of a "Stop-and-Go" penalty, the driver must stop in the designated area where they shall remain for the prescribed stop time.

Unless notified otherwise by a Stewards' Bulletin for a particular event, the designated area for "Stop-and-Go" penalties to be served will be in the respective competitor's pitlane working area. Competitors are responsible for ensuring that their car stops for the prescribed stop time, and this will be checked by the Timekeepers. When the prescribed stop time has elapsed, the driver may re-join the race.

However, unless the driver was already in the pit entry for the purpose of serving a "Drive-Through" or "Stop-and-Go" penalty, they may not carry out the penalty while the Safety Car has been deployed. The number of times the driver crosses the control line behind the Safety Car will be added to the maximum number of times they may cross the control line on the track.

Whilst a car is stationary in the pitlane as a result of incurring a "Stop-and-Go" penalty it may not be worked on. However, if the engine stops it may be started after the prescribed stop time has elapsed.

- Should either a "Drive-Through" or "Stop-and-Go" penalty be imposed and notified during the last five laps/ten minutes or after the end of the race, or cannot be imposed for operational reasons, then at the discretion of the Stewards the procedure above may not apply and the penalty may be converted to a time penalty of a minimum of 30 seconds in the case of a "Drive-Through" penalty or a minimum of 35 seconds plus any penalty time in the case of a "Stop-and-Go penalty" (unless different conversion times are specified in a Stewards' Bulletin at an event) which will be added to the elapsed time of the car concerned.
- For any breach of the regulations during free practice, the Stewards may (as an alternative to or in addition to any other penalty) impose a "Stop-and-Go" penalty which they may order to be taken at the start of the

Qualifying practice session, in which case the car concerned may not leave its pitlane working area at the start of the Qualifying session until the prescribed stop time has elapsed.

- Any breach or failure to comply with the above procedure may result in the car being disqualified.

Should the Stewards impose a drop of grid position on a driver for a future race, the penalty remains with the driver even if the driver moves to another team and/or car.

In accordance with Article 12.8.3 of the FIA International Sporting Code, any fines imposed by the Stewards are payable within 48 hours of their notification to the FFSA (the parent ASN of the International Series).

Where a fine is imposed, continued participation in the Series beyond the event at which the fine was imposed may not be permitted until any fine imposed is paid in full.

### **PCCF points licence:**

In accordance with Article 12.4 of the International Sporting Code, the penalties that may be imposed are as follows:

- Warning
- Fine
- Drop of grid position(s)
- Time penalty
- Penalty lap(s)
- Drive-through penalty
- Disqualification
- Exclusion
- Reprimand (blame)
- Obligation to accomplish some work of public interest
- Deletion of a Driver's qualifying and practice lap(s)
- Obligation for a Driver to start a race from the pit lane
- Drop of place(s) in the classification of the Competition
- Stop-and-go or stop-and-go with a prescribed stop time
- Suspension

Each driver has a capital of 12 points at the beginning of the season.

When a driver commits an infringement of the regulations concerning the standards of conduct or the Code of Conduct of the Series, the stewards may impose, in addition to a sporting penalty, the following sanctions:

- A reprimand
  - Any driver who accumulates three reprimands for infractions relating to the standards of conduct or behaviour will be demoted by 5 places on the starting grid for the next race.
  - Once the penalty has been served, the driver concerned will return to a 0 reprimand count.
- Withdrawal of points on the "PCCF" licence
  - If a driver obtains a capital of 0 on this points licence, the stewards will impose an additional penalty. This penalty will force the driver concerned to start from the back of the grid for the next race.
  - Once the penalty has been served, the 12 points capital will be restored to the driver concerned.

In accordance with Article 12.4 of the International Sporting Code, decisions to withdraw points are not subject to appeal.

The Organising Committee may penalise a driver for non-compliance with the PCCF Code of Conduct by withdrawing points.

For each penalty imposed by the Stewards against a Competitor or Driver, the Series Organiser may decide to apply an additional penalty of up to permanent disqualification from the Porsche Carrera Cup France, without refund of the paid commitments.

1 <sup>st</sup> infraction:	Warning
2 <sup>nd</sup> infraction:	One race suspension
3 <sup>rd</sup> infraction:	Disqualification from the Porsche Carrera Cup France

## 17.9 The track

Drivers must use the track at all times and may not leave the track without a justifiable reason. For the avoidance of doubt:

- The white lines defining the edge of the track are considered to be part of the track.
- A driver will be judged to have left the track if all four wheels of the car go beyond the white line.
- Any kerbs installed beyond the white lines are not considered to be part of the track.
- Any report made by a duly appointed Judge of Fact regarding a driver having left the track may not be contested by the Competitor or the Driver concerned and a Judge's statement of fact must be accepted as a fact unless later corrected by him or over-ruled by the Stewards. The Race Director and/or the Stewards may, at their sole discretion, review any report for the purposes of ensuring accuracy and consistency. This does not preclude the Stewards from exercising their right to over-rule, or accept a correction from, a Judge of Fact.

The following penalties may be applied:

### **During Free Practice:**

- Any driver identified by a Judge of Fact as having left the track (unless for reasons beyond his control) may have that lap time (and where appropriate the following lap time) deleted by the Race Director or Stewards.
- Any driver who repeatedly leaves the track may be reported to the Stewards who may impose a penalty.

### **Qualifying sessions:**

- Any driver identified by a Judge of Fact as having left the track (unless for reasons beyond his control) may have that lap time (and where appropriate the following lap time) deleted by the Race Director or Stewards.
- Any driver who repeatedly leaves the track may be reported to the Stewards who may impose a penalty up to and including a deletion of all lap times or a drop of grid positions for the race. It is not a condition that the driver must have been shown the Black and White flag before a penalty is applied.

### **Races:**

- Any driver identified by a Judge of Fact as having left the track (unless for reasons beyond his control) on a number of occasions will be shown the Black & White flags as a warning. The warning will also be visible via a message on the timing screens.
- Any driver who repeatedly leaves the track may be reported to the Stewards who may impose a penalty, the minimum being a race time penalty of 5 seconds. Further offences may result in further penalties. It is not a condition that the driver must have been shown the Black and White flag or that the team manager of the driver received a radio warning from the Race Director before a penalty is applied.

At the absolute discretion of the Race Director, a driver may be given the opportunity to give back the whole of any advantage he gained by leaving the track, this should be done in the shortest possible time.

## 17.10 Disciplinary Sanctions

Porsche France giving special importance to the sporting spirit of the Porsche Carrera Cup France, any finding incidents in the paddock and on the track (provocations of all kinds, verbal threats, etc.) and/or behavioural unsportsmanlike or inconsistent with the spirit of the Porsche Carrera Cup France (breach of morality and ethics in sport, nuisance to the best interests of motorsport, moral or material prejudice suffered by Porsche or partners of the Porsche Carrera Cup France, etc..) from a competitor, driver or his entourage will be reported to the stewards and will be capable of application of the following penalties:

- Rejection of commitment(s) to the following meeting(s) for the competitor or driver concerned by the actions of those around him or her team, in accordance with Article 3.14 of the FIA International Sporting Code.
- Proposing to the stewards the disqualification of the competitor or driver concerned by the actions of those around him or his team from the running meeting.
- Request from the stewards for the seizure of the Disciplinary Commission.
- Financial penalty be paid to Porsche France.

## **17.11 Environmental regulations**

### **Tyre Cleaning**

Tyre cleaning water is only allowed if all waste water is collected and disposed of in the designated area(s).

### **Collection of Hazardous Liquids**

It is the Competitor's responsibility to ensure at all times during events that hazardous liquids are collected by suitable containers or absorbing sheets and disposed of in the designated area(s). It is recommended to cover the complete working area below the cars in the tent with absorbing sheets. Any hazardous liquid container needs to be stored in a separate container that holds any spillage or overflow.

## **18. Safety**

### **18.1 Extrication exercise**

At each event, the Series Organizer, in conjunction with the event medical personnel, may elect to hold an Extrication Exercise. The Series Organizer shall, by rotation, nominate a Team and Driver to take part in the exercise. The Team and Driver must comply with this request and have the nominated car and driver, with all racing equipment, available at the designated date and time in the Series paddock, in full race condition. Failure to comply with this regulation may result in a penalty.

The Series Organiser or the Race Director, at their sole discretion, may elect to replace the Driver with a member of the medical team undertaking the exercise.

### **18.2 Pit lane safety**

The maximum speed in the pit lane during practice, qualifying and each race is specified by the promoter in the Supplementary Event Regulations and will be monitored by the Race Director and the Stewards. Drivers exceeding the permitted maximum speed during free practice qualifying sessions or race may be penalised with a fine of EUR 50 ex-VAT for each km/h over the specified limit. The penalty is to be paid to the national ASN. To this financial penalty may be added a "Stop-and-Go" penalties during either of those sessions or a drop of grid positions for the race. Drivers who repeatedly exceed the permitted maximum speed in the pit lane during free practice/qualifying and races may face additional penalties for speed limit violation. "Driver-Through" or "Stop and Go" penalties may be issued if the permitted maximum speed in the pitlane is exceeded during a race.

The use of safety stands (securing the car from dropping unintentionally from the air jacks) for any type of work underneath the car is strictly enforced. This applies for any operation requiring any part of a team member's body to be under any part of the car (e.g. hands or arms under the wheel arch). Engines must not be running while a car is on jacks or other temporary supports. Any non-compliance will be reported to the Stewards and penalized at the full discretion of the Stewards.

All work on cars in the pitlane must only be undertaken in the Competitor's own working area in the inner (working) lane. No work may be undertaken in the outer (fast) lane or elsewhere in the inner (working) lane. When cars are waiting in the outer (fast) lane prior to exiting the pitlane at the start or restart of any practice or qualifying session or race, no work of any description may be undertaken on the car. It is permitted to use a forced air blower to cool the Driver, but any such cooling equipment must be removed from the outer (fast) lane before the pitlane open signal is given.

The outer (fast) lane is to be kept unobstructed to allow safe passage of cars at all times. It is the responsibility of each Competitor to release their car from the working area only when it is safe to do so. Cars in the fast lane have priority over those leaving the working lane.

The position of the cars in the pitlane will be announced in the Supplementary Regulations as well as during the drivers' briefing by the race director. This position must be respected by all the competitors during free practice sessions,

qualifying sessions and during the races. When a car is ready to leave its pit area, the team members are responsible for ensuring that the car is released safely and without impeding other cars.

The onus shall be on all drivers to take due care and drive within the pitlane speed limit. Drivers must respect the designated pit entry and must not cross the white line at pit exit, details of which will be provided in the Drivers' Briefing.

All equipment must be kept in a safe position towards garages as soon as cars leave their pit areas at the start of and during practice, qualifying and races.

No equipment may be positioned on top of the pit wall or any adjacent structure, unless it is firmly secured in position.

Competitors, team members and drivers are responsible for the good conduct and safety of their guests in the pitlane area. Competitors, team members and drivers must ensure that their guests always respect the pitlane regulation and be vigilant at all times.

Competitors, team members and guests must wear closed footwear in the pitlane at all times, open footwear is not permitted. It is strongly advised that long trousers (not shorts) are worn by team members. Competitors are responsible for informing their guests of suitable clothing standards when in the pit lane, including footwear and a recommendation for long trousers (ladies and gentlemen) together with covered shoulders.

Guest must carry the correct credentials at all times. Any guest found in the pitlane without the correct pass will be excluded from the pitlane and the Competitor will be reported to the Stewards.

No person under the age of 16 years of age is permitted in the pitlane at any time.

To this end, it is the responsibility of each competitor and/or driver to give a briefing to each individual guest regarding the pitlane safety.

### **18.3 General safety**

Drivers are strictly forbidden to drive their cars in the opposite direction to the specified direction unless this is necessary in order to move the car from a dangerous position. A car may only be pushed to remove it from a dangerous position as directed by the marshals. No car may be reversed in the pit lane under its own power.

At any time whilst on track, drivers may only use the track and must always observe the provisions of the International Sporting Code and these regulations relating to driving conduct on circuits.

Official instructions will be given to drivers by means of the signals set out in Appendix H of the FIA International Sporting Code. Competitors are responsible for observing and complying with these at all times. At circuits where flag signals are supplemented by light panels/signals, both means of signalling will be deemed to have regulatory value. In case of conflicting signals between the flags displayed by marshals and the light panels/signals, drivers must comply with the requirements of the signal with the highest level of safety. In order of precedence this means: Red Flag, Safety Car, Double Yellow Flag, Single Yellow Flag, Green Flag.

If a car stops during any session or race it must be removed from the track as quickly as possible so that its presence does not constitute a danger or hinder other Competitors. If the driver is unable to drive the car from a dangerous position, it shall be the duty of the marshals to help. However, if any mechanical assistance is required to move the car then the car will not be permitted to re-join. A driver who abandons a car must leave the steering wheel in place.

Any driver entering a gravel trap and then re-joining must avoid bringing gravel onto the track and particularly onto the racing line. Any driver ignoring this instruction may be referred to the Stewards.

In free practice and qualifying, any car that drives through and out of a gravel trap must go directly to the pits to be checked before continuing the session. In the race, an instruction will be issued by Race Control if a car must pit to be checked.

In all cases when leaving a gravel trap, a driver must re-enter the track offline and avoid depositing gravel on the racing line.



Should any session or race run into dusk or darkness all cars must, on the Race Director's instruction, have two front headlights and two rear red lights illuminated. Should any lights fail during the session, no penalty will be imposed but the Race Director may stop a car using the black and orange flag if he considers this is causing an immediate safety issue.

Throughout all sessions there will be a green/red light at the pit exit. Cars may only leave the pitlane when the green light is on.

Any driver intending to leave the track or to go to his pit or the paddock area must signal his intention to do so in good time making sure that he can do this without danger.

In the Drivers Briefing, the Race Director may define a time and place where practice starts will be permitted. It is forbidden to undertake a practice start at any other time or place or if practice starts have not been authorised.

At the end of any session or race, each driver may cross the Control (Timing) Line only once before leaving the track.

All drivers must complete and pass all sections of the Edubreak e-learning test administered by the Series Organiser. An E-Mail link will be provided by the Series Organiser. The competitor must ensure that each driver has completed the test before taking part in the driver's first competition of the Series.

All personnel working on set-up or dismantling of the paddock area must wear high-visibility clothing.

All paddock vehicles that require the personnel to be on the roof (i.e. for affix awnings or flag poles/flags) must have the relevant safety equipment fitted. Any personnel on the roof must wear the relevant safety harnesses which be affixed to the equipment on the roof.

# Part 2: Technical Regulations

## 1. Technical Series regulations

### 1.1 Summary of the eligible groups / classes

The Porsche Carrera Cup France is One makes series without distinction of group or class.

Only cars of the type/model Porsche 911 GT3 Cup, type 992 (a special series produced by Porsche AG), of the model year 2021, 2022 and 2023 which fully comply with these Regulations are eligible to participate.

The vehicles must meet the technical specifications of these Regulations and Appendix J of the International Sporting Code in full and must possess a valid and registered FFSA vehicle pass (or the corresponding document of another ASN associated to the FIA or be waiting for a FFSA pass).

A change of vehicles has to be applied for in writing by the entrant and must be approved in written form by the Series Organiser prior to the change. The decision to approve a change of vehicle is at the absolute discretion of the Series Organiser.

### 1.2 Principles of the technical regulations

In accordance with:

- Art. 251 and 277 Appendix J (Group EII-SH) of Appendix J (FIA ISC)
- General provisions, definitions and clarifications regarding the technical regulations (FFSA standard Technical Regulations)
- Technical rules and regulations of the 2023 Porsche Carrera Cup France
- Technical information published by the Porsche Carrera Cup France organisation in 2021, 2022 and 2023.
- Technical manuals of the eligible vehicles
- Spare parts catalogue of the eligible vehicles

Should there be any discrepancy between the provisions of these technical regulations and any relevant technical information notes or the spare parts catalogue, then these technical regulations will take precedence.

Any requirements specified in a technical manual, technical information notes and/or spare parts catalogue may be updated by the Series Organizer.

For software information, only the latest version is valid but Setups (based on the latest version) can be adjusted.

Any rules can be modified for any specific event via an official bulletin issued by the stewards.

It is recognised that spare parts listed in the parts catalogue may be subject to a change of part number during the season. Therefore a spare part which is identical to that shown in the parts catalogue (and which has the same function, working principle and location in the vehicle) but which bears a different part number may be used, subject to prior approval by Porsche AG Aftersales Department. Such approval shall be at the sole discretion of Porsche AG and it is the responsibility of the competitor to ensure such approval, where granted, is documented and retained for inspection by the Technical Scrutineers.

Parts shown in Attachment 7 which have different part numbers to, but the same function as, the original part in the car or in the spare parts catalogue are allowed to be used for the originally intended function and in the originally intended position.

### **1.3 General / preamble**

Everything that is not expressly permitted in these Regulations is prohibited. Any addition or removal of material, heat treatment or coating to alter the properties of a part or component and/or its dimensions is forbidden. Mounting a part in a different way or location than the original delivery condition is forbidden.

Permitted modifications must not result in any illegal modifications or infringements of the Regulations.

Any permitted changes may only serve the intended purpose.

The decision of the Sporting Committee shall be final regarding any interpretation of these regulations.

The Series Organiser reserves the right to amend and extend these regulations (in consultation with the FFSA).

The installation of any permitted optional parts or systems must be in accordance with the manufacturer's instructions and must be approved by the Technical Scrutineers. Any such installations remain the sole responsibility of the participant. At the Technical Scrutineers discretion, any competitor must, if requested, remove any optional part or system.

### **1.4 Driver's Equipment**

Driver equipment must be worn at all times whilst the driver is seated in the car in the pre-grid area, the pit lane and on the track. It is compulsory to wear overalls in compliance with FIA 8856-2000 or FIA 8856-2018 standards as well as underwear (with long sleeves and legs), balaclava, socks, shoes and gloves in compliance with FIA regulations.

Furthermore, wearing a helmet in compliance with the FIA Regulations (Appendix L of the ISC) is compulsory, as well as the use of a head restraint system (e. g. HANS).

All driver equipment must be worn in accordance with the manufacturer's instructions (balaclavas inside race suits, FHR systems correctly secured, etc). Failure to do so may result in the driver being shown the black flag and/or being ordered by the Race Director or the Stewards to immediately rectify any error or omission.

#### **1.4.1 Frontal Head Restraint System (FHR, as HANS or comparable system)**

The use of an FIA approved head restraint in compliance with FIA list no. 29 is compulsory for all Porsche Carrera Cup France races.

Responsibility for the necessary modifications to the driver's equipment in order to enable use of such a system and installation of same in the vehicle in compliance with the manufacturer's instructions lies solely with the participant.

The relevant manufacturer's certificate is to be presented during the technical scrutineering.

#### **1.4.2 Drinking system**

A drinking system may be used. Installation needs to be fixed using metal hardware and be able withstand a crash of 30G. Prior to the installation it must be approved by the Technical Scrutineer.

#### **1.4.3 Cooling system**

A cooling system with cooling vest may be used. Installation needs to be fixed using metal hardware and be able withstand a crash of 30G. Prior to the installation it must be approved by the Technical Scrutineer.

The installation according to the manufacturer's instructions is the sole responsibility of the participant.

Any other cockpit cooling system than the Porsche genuine one is prohibited.

## **1.5 General Regulations**

### **Permitted modifications and built-in installations**

The only work which is allowed to be carried out on the vehicles is that necessary for its normal servicing, or for the replacement of parts worn through use or accident.

The limits of the modifications and installations allowed are specified hereinafter. Any part worn through use or accident may only be replaced by identical Porsche Genuine Parts that are assigned to the eligible vehicles in compliance with Item 2.1. The Porsche Genuine Parts are specified in the valid spare parts catalogue in each case.

The use of components manufactured by Porsche AG for other groups of vehicles (e.g. Porsche road vehicles) is also prohibited.

The use of any items described as "optional" in the parts catalogue is prohibited, as long as their use is not in particular allowed by these technical regulations.

Throughout the vehicle, the standard fastening components such as nuts, bolts, washers, lock washers, spring washers and splint pins must only be replaced by Porsche Genuine Parts.

The service and replacement intervals and adjustment values specified by Porsche AG (see Technical Manual) are to be observed.

The Series Organiser may allow modifications that do not correspond to the series production status on all or individual vehicles, providing these do not permit a competitive advantage (e.g. for the attachment of cameras; radio installations, etc.). The entrant must make written application to the Series Organiser and receive written authorization before making any such modification.

## **1.6 Minimum weights and ballast**

It is the entrant's responsibility to ensure that at all times during the event the mandatory minimum combined weight of the vehicle with empty fuel tank, driver equalization weight and the driver (together with all driver equipment) is reached.

At no time during an event is the car weight permitted to be less than the mandatory minimum weight when the car is either presented for technical scrutineering, in on the track or in Parc Fermé.

The mandatory minimum car weight and minimum driver (together with all driver equipment and equalization weight) will be announced per bulleting at the end of technical scrutineering of the first event.

The minimum weight must also be observed when the levels of operating liquids are under the minimum level.

The Technical Scrutineers shall specify a weight scale for checking the weight of the vehicles and drivers. It is referred here as the "official scale". The official scale is located in the technical scrutineering tent of the Porsche Carrera Cup France. This is also the weighing area.

Every year, the official scales are checked and certified by an independent laboratory.

### **1.6.1 Baseplate auxiliary weight**

If the original base plate does not contain the necessary holes for the mounting positions as indicated in these regulations, they can be added after consultation with the Technical Scrutineers. The mounting holes can only be added in the necessary positions to satisfy the requirements of these regulations.

### **1.6.2 Auxiliary weight**

The installation of original Porsche ballast weights is permitted on the auxiliary weight base plate at the position of the passenger's seat in accordance with the illustration in Attachment 3.

The ballast weights are identified by spare part numbers in the spare parts catalogue and the reference table in Attachment 7. No other ballast weights or locations are permitted.

### **1.6.3 Minimum vehicle weight**

The minimum weight of a vehicle shall consist of:

- The weight of the vehicle (with empty fuel tank)
- The weight of the inboard camera, the radio system assigned by the Series organiser of the weight of the respective substitute ballast.
- The installed additional weights (excluding driver equalization weight)

### **1.6.4 Minimum driver weight**

The minimum weight of the driver is 90kg and consists of:

- The driver
- The compulsory personal equipment of the driver (art. 1.4)
- The driver equalization weight if applicable.

It is the driver's responsibility to ensure that the sum of the installed equalization weight plus his/her actual weight, plus the parts of his/her personal equipment (only clothes, HANS and helmet) is at least reached at all times.

### **1.6.5 Determining the total weight of the driver and vehicle**

The Technical Scrutineers may in their absolute discretion decide to weigh the vehicle and driver separately or in combination.

If the vehicle and the driver (together with all driver equipment) are weighed in combination, the weight plus 2.0 kg of weighing tolerance shall be added, and the product shall be referenced against the mandatory minimum combined weight, which must be reached.

If the vehicle and the driver (together with all driver equipment) are weighed separately on the official scale, the two weights plus 2.0 kg of weighing tolerance for the car and 0.5 kg of weighing tolerance for the driver weight shall be added and the product shall be referenced against the mandatory minimum combined weight, which must be reached.

Prior to weighing a vehicle, the Technical Scrutineers shall remove the remaining fuel from the fuel tank, after taking a fuel sample for analysis.

### **1.6.6 Weight changes during qualifying and race**

During the qualifying practices and the race, the weight of the vehicle can only be altered by:

- Changing from slick tyres to wet tyres or vice versa,
- Consumption of consumable materials and fluids.

On the way from the circuit to the "Parc Fermé" and in the "Parc Fermé" itself, and on the way to the post-race technical scrutineering under no circumstances is weight allowed to be added to the vehicle or the driver.

### **1.6.7 Verification of the minimum weights by the participants on the official scale**

Entrants have the opportunity to check the weight of their vehicles and drivers during the event on the official scale with the permission of the Technical Scrutineers. Only the measurements recorded by the Technical Scrutineers shall be deemed accurate for the purposes of compliance with the regulations.

### **1.6.8 Personal protective driver equipment during weighing**

During the weigh-in, each driver must wear his/her complete driver apparel – as set out in Annex L, Chapter III of the ISC – plus the mandatory head restraint system.

### **1.6.9 Weighing of vehicles**

The weighing procedure of vehicles and drivers is conducted in accordance with the current FFSA policy for the weighing of vehicles. The vehicles are weighed as follows:

- Weighing of vehicles is carried out regularly on the official scale of the Porsche Carrera Cup France.
- After the free practices, qualifying and races, weighing can also be done on the scale of the organiser of the meeting, which is located stationary in the Technical control pit. Any differences between these scales are taken into account by the Technical Scrutineers. If the weighing on the organizer's scale indicates that the car in question might be found underweight on the official scale – considering the tolerance – this car, the driver and his protective equipment must again be weighed on the official scale which is the only result to be taken into consideration and to be binding.
- If a driver is given the signal that his car has been selected for weighing, he/she must take the shortest route possible to the weighing area and turn off the engine.
- The driver or a team member will receive written confirmation of the measured weights. During weighing the driver is not permitted in any way to influence the weighing result.

Any appeal against the observed weight must be immediately submitted to the Technical Scrutineers after receiving the report.

If a vehicle cannot reach the weighing area under its own power, then the scrutineers can assign people for this purpose.

### **1.6.10 Leaving the weighing area**

Without the consent of the Technical Scrutineers, the driver is not permitted to leave the weighing area and the vehicle is not allowed to be removed.

### **1.6.11 Weighing after breakdown and vehicle remaining on circuit during qualifying and race**

If a vehicle breaks down during the qualifying session or the race and the driver leaves his/her vehicle, he/she must go directly to the weighing area to determine his/her weight.

### **1.6.12 Determining the driver weight**

After every qualifying and races all drivers must go immediately from the "Parc Fermé" to the weighing area to determine their weight. Drivers who are approached by the TV partner for an interview may interrupt their walk to the weighing area for the duration of the interview. Drivers who go to the podium can be weighed on the organiser scale. Any differences between the organiser scale and the official scale will be taken into account. Drivers who do not go directly to the weighing area to be weighed will be reported to the stewards of the Event. The stewards of the Event will take the final decision regarding a punishment.

The drivers will be weighed individually. Once the driver leaves the weighing area, this will be deemed implicit acceptance of the recorded weight. Any appeal against the observed weight must be immediately submitted to the Technical Scrutineers.

### **1.6.13 Replacement and loss of vehicle parts**

All vehicle parts that were replaced during the free practice, qualifying session and race must be presented to the Technical Scrutineers without request for inspection. The parts that were removed from the vehicle will be marked by the Technical Scrutineers if necessary and are not allowed to be modified in any way afterwards. These parts must remain in the pit or in the technical scrutineering tent in sight of the Technical Scrutineers or their assistants until released by the Technical Scrutineers. These parts can be considered when determining the weight instead of the replaced parts.

In case of a loss of coolant, the final weight of the car may be only determined by draining all remaining coolant liquid (from engine, coolant reservoir, all radiators, all coolant hoses and connectors) and adding 24 kg to the measured weight of the car.

Should a car be presented for weighing with lost or damaged parts it shall be at the sole discretion of the Technical Scrutineers to determine which, if any, parts should be replaced prior to the car being weighed.

#### **1.6.14 “Parc Fermé” rules for vehicle weighing**

Vehicles that have been specified for weighing are subject to “Parc Fermé” regulations. It is forbidden to add or remove any substance to/from the vehicle after it has been selected to be weighed. The same applies during the weighing process and after the end of the race. Excluded are actions of the Technical Scrutineers.

It is the entrant's responsibility to ensure that the race vehicle entered by him can be brought directly to the weighing area when instructed by the stewards or the Technical Scrutineers at any time during the event. In any case, Parc Fermé rules apply to the vehicle from the moment of the order until the termination of the weighing process.

#### **1.6.15 Weighing in below the minimum weight**

If, during the post qualifying or post-race weighing procedure, the combination of vehicle and driver (including driver equipment) is found to be below the currently applicable minimum weight, the vehicle and driver (including driver equipment) will immediately be weighed together for a second and a third time on the same scales and in the same condition after the same session and with the same measuring method (car and driver together or separated).

The maximum value of the 3 weights recorded is regarded as the actual weight of the combination of vehicle and driver (including driver equipment).

Falling below the minimum weight will be reported to the stewards and will be penalized.

#### **1.6.16 Regulations on the route to and in the weighing area**

Parc Fermé rules apply to the route to the weighing area and in the weighing area itself. In addition to the technical scrutineers, only the responsible sporting marshals and their helpers are permitted to enter the weighing area. In this area, the only activities on the vehicle are those expressly permitted by the aforementioned persons. If a vehicle is not presented for weighing despite a request, the Technical Scrutineers will inform the stewards.

### **1.7 Emissions Regulations**

The cars must be equipped with a catalytic converter as supplied by Porsche AG and in accordance with the FFSA exhaust gas emission regulations.

### **1.8 Noise Regulations**

The car will race without pre-silencers, but this element must be stored in the truck of the team in case of need, on each meeting. The regulation of each meeting will define the use or not of this pre-silencer.

With pre-silencers, the noise generated by the car must not exceed 105 db(A), measured via the FFSA procedure.

Without pre-silencers, the noise generated by the car must not exceed 115 db(A), measured via the FFSA procedure.

### **1.9 Advertising regulations and starting numbers on the car**

#### **1.9.1 Series advertising and competition numbers**

(a) The advertising decals, logos, drivers' names, starting numbers and national identification markings as specified by the Series Organiser must be fixed on all competing cars throughout the entire event. The size, type, quantity and positioning of the identifications are determined and announced in the “2023 Sticker Regulations” (Appendix 2).

The registered entrants will be informed about their starting number before the first race. The starting numbers remain the same for all races.

The obligatory badges as specified by the Series Organiser, must be affixed to Drivers' racing overalls during all free practice, qualifying sessions and races of the Series. The size, type, quantity and positioning are determined and announced in the "2023 Badge Regulations."

The "Badge Regulations 2023" and the "Sticker Regulations 2023" are part of these Regulations (see Attachments 1 and 2). Any breach of these Regulations may result in disqualification from the competition.

- (b) All surfaces that are not occupied as specified in the Appendix 2 "2023 Sticker Regulation" shall be available for the entrants' own advertising labels. The clearance between such advertising and the mandatory labels and starting number shall be a minimum of 30mm.
- (c) Vehicles of a team with virtually identical liveries must have clearly different wing mirror colouring. The mirror colours used to identify the vehicles are to be retained for the entire season.

The Competitor is responsible for ensuring that the stickers on the entered cars comply with the applicable legal regulations.

### **1.9.2 Partnerships**

- (a) Teams must not enter into partnerships with companies who are either in competition to Porsche AG, its parent or partners companies, the Porsche France Carrera Cup France (or its official partners) or who are involved in a legal dispute with Porsche AG or a company associated with Porsche AG. The teams are therefore obliged to notify potential partnerships to Porsche France in advance.
- (b) The use of advertisements for companies, their products, services or brands that are competitor products, services or brands of Porsche AG, their associated companies or the Series sponsors on vehicles, helmets, race suits and other driver equipment, on team vehicles or on team clothing or any other kind of advertising for these companies, products or services is strictly prohibited.
- (c) The use of advertisements for companies in the tobacco and sex industry, or political or religious advertising, or private betting and gambling operators on cars, helmets, race suits and other Driver equipment, on team vehicles or on team clothing or any kind of advertising for these companies, products or services or anything that may be deemed by Dr. Ing. h.c. F. Porsche AG to bring the company and/or the Series into disrepute is strictly prohibited.
- (d) The Competitor is obliged to notify the Series Organiser of all potential partners/sponsors and obtain written (text form sufficient) approval from the Series Organiser for their use. The Series Organiser is entitled to prohibit Competitors from displaying or promoting in any manner the details of any unapproved partners/sponsors.
- (e) The entrant and team partners/sponsors shall grant to the Series Organiser and the Series sponsors all materials depicting the championship and/or rights to use sporting success for advertising purposes, without paying separate fees for this purpose.

The entrant (team) is responsible for ensuring that the stickers on the entered vehicles comply with the applicable legal regulations.

Porsche France is entitled to prohibit teams from entering into a partnership if the potential partner falls into one of the above two categories or going against the values conveyed by Porsche France.

Contravention of any of the advertising regulations may result in a fine of at least EUR 1,000, and/or refusal to participate in any competition or disqualification from the competition, in each case at the discretion of the stewards.



## 1.10 Safety Equipment

The vehicles must possess the following safety equipment:

- Category EII-SH (Art. 277) of the Appendix J of the International Sporting Code.

The on-board fire extinguisher system must be switched into position "Armed" and the red LED illuminated from the moment a car leaves its team area to travel to the pre-start area for each session and must not be switched off until the car is returned to the team area or Parc Fermé after the session.

### **Note:**

For events held in all of the countries listed in the Series calendar (article 7.1), the Series Organiser is responsible for observing and implementing (or agreeing any deviation from) any additional safety regulations of the respective ASN.

## 1.11 Fuel

The only permitted fuel is commercial, unleaded fuel in compliance with Art. 252.9 of the Appendix J (ISC) which must comply with DIN EN 228 and must be from a supplier specified by the Series Organiser. A new supplier can be designated for each event (fuel pumps, tanker, or similar). Only this fuel is permitted to be used for the duration of the event. The official fuel supplier will be announced in the team info and published on the official board in the Porsche Carrera Cup France truck.

### **Fuel controls**

The Technical Scrutineer shall be entitled to take fuel samples from a participant's vehicle at any time during the event. At any time of the event until the end of the protest deadline (subject to removal of fuel for the weighing procedure), the entrant must ensure that the minimum quantity of 2L of fuel can be taken from the corresponding removal point (fuel removal valve) in the tank (in accordance with the general prescriptions of the FFSA). The required quantity of fuel must be able to be taken, from the removal point defined above, within a maximum period of 10 minutes after the start of defuelling.

These samples must be identical to the reference fuel taken from the petrol pumps designated above. The laboratory in charge of the sample analysis will be chosen by the Series organiser.

If the Technical Scrutineers order that a car be defueled (for example to check the minimum weight of the vehicle without residual fuel), a fuel sample must be taken prior to defuel the vehicle.

### **Refuelling, refuelling installations and control**

All additives are prohibited. Fuelling and refuelling during free practices, qualifying and the race is forbidden. All chemical or thermal changes to the fuel are forbidden.

Throughout the race event the temperature profile of the outdoor air temperature will be recorded by the Technical Scrutineer by the use of special temperature recorder defined by Porsche France. The minimum value will be posted on the official notice board before the first session of each day. At no time is the fuel temperature allowed to be less than the lowest outdoor air temperature of the last 24 hours.

Any operations involving the handling of fuel require the car and all equipment must be grounded to earth properly and at least two 9kg ABC Dry Powder or alternatively two 5kg CO2 fire extinguishers with stand-by personnel (not involved in any fuel operations) must be present in this area.

Fuel must be added or removed into or from the fuel cell of the car using a closed-circuit fuelling system manufactured by a specialist company (the Series Organiser reserves the right to inspect any system being used and approve or disapprove its use). The exact specification of the closed-circuit fuelling system may be chosen by the team according to their needs (size, pump speed, etc.) however no safety aspect of the system is allowed to be changed. The fuel will only be supplied in drums and may only be added and removed from the drums with the same closed-circuit fuelling system specified using a suction pipe.

Should there be any circumstances where a team is unable to use the closed-circuit fuelling system, then any fuel operations must be performed outside the team tent in a fenced and gated area of at least 5m in each direction of the car. All personnel working in this area wear full fireproof clothing (including shoes, gloves, goggles, balaclavas, etc.). Under no circumstances must members of the public, team guests or unauthorised personnel be allowed in this area at any time during the fuelling operation; it is the responsibility of the team to ensure that such persons are excluded from the area. The Porsche Carrera Cup France organisation is excluded from any liability in case of problems.

Any work requiring the fuel cell to be opened may only be performed after all fuel has been completely removed from inside the fuel cell and with appropriate protection and fire extinguishers being present at the respective work place. Smoking and hot works are prohibited when any operation involving fuel or the fuel cell is in progress.

## 1.12 Definitions

In addition to the definitions in the General prescriptions of the FFSA regulations, the definitions set out in Appendix J (Article 251 ISC of the FIA) shall apply.

## 2. Special Technical Requirements

### 2.1 General information

Technically identical cars with the designation Porsche 911 GT3 Cup (Type 992), built by Porsche AG in a small production run on the basis of the Porsche 911 GT3, shall be used for the Porsche Carrera Cup France. Only vehicles of model year 2021, 2022 and 2023 (see following general description) are permitted.

#### **General vehicle description:**

Porsche 911 GT3 Cup (type 992), MY 2021, 2022, 2023.

**Concept:** Single-seated, near-standard race vehicle based on the Porsche 911 GT3. For further general descriptions, the entrant shall refer to the respective paragraph of these technical regulations.

#### **Important information:**

Certain special parts used in the Porsche 911 GT3 Cup cannot be obtained via the Porsche dealer organisation but instead can only be obtained from the Porsche Motorsport Parts Sales Department at Porsche AG, or from the Porsche Carrera Cup France's customer service truck present on each event of the season, or also from ORECA in Magny-Cours.

**Benjamin CHEVILLARD**

**Spare Parts Manager**

Groupe ORECA

Technopole du Circuit

58470 Magny Cours

Tél. : + 33 (0) 3 86 21 86 10

Mail : [b.chevillard@oreca-magnycours.fr](mailto:b.chevillard@oreca-magnycours.fr)

The car must comply with the requirements of these technical regulations. Technical inspection of the vehicles will be undertaken by the Technical Scrutineer.

In addition to the technical regulations forming Part 2 in these Series regulations, the following specific technical regulations are applicable:

## **2.2 Engine**

### **2.2.1 General description**

- Water-cooled six-cylinder rear-mounted boxer engine.
- Displacement 3,996 cm<sup>3</sup>; stroke 81.5 mm; bore 102 mm; max rpm 8750 rpm
- Single throttle butterfly system
- Intake manifold with two resonance flaps
- Dry-sump lubrication with oil-water heat exchanger
- Race exhaust system with certified catalytic converter
- Engine control unit Bosch MS 6.6
- Single-mass flywheel
- Required fuel quality: minimum 98 octane, unleaded, to E20

The engines are sealed at Porsche AG prior to delivery. A vehicle with an unsealed engine or with a damaged seal is not permitted to participate in the Porsche Carrera Cup France under any circumstances.

Only a professional approved by Porsche AG will be allowed to undertake work on the engine, requiring opening the seals. An engine change has to be approved in writing by the Series Organiser prior to the change. Engines can be called in and inspected at the instructions of the Technical Scrutineers, at the expense of entrants.

Engines inspected or reviewed by the professional approved by Porsche AG will be sealed before delivery.

### **2.2.2 Engine electronic control units**

Throughout the entire event, only the engine electronic control units coded and sealed by the Series Organiser for the event are permitted to be used.

The engine electronic control unit (including the complete wiring harness) must be used without modifications. The Series Organiser or the Technical Scrutineers reserve(s) the right to check or exchange the engine electronic control unit or record the engine characteristic data at any time during the event. The Series Organiser reserves the right to reprogram the electronic control units and to seal the plug-in connectors for reading the electronic control units at any time of an event. It is thus ensured that the status of the program and data is identical for all participating vehicles.

It is the Competitors responsibility to ensure that the engine electronic control unit is programmed and only used with the software MS66\_PAG992\_GT3\_0112\_992GT3CUP\_hp56\_SC008 during each event.

The Series Organiser needs to be informed in writing before each event of VIN and ECU number if an electronic control unit has the capability of traction control and is used in a PCCF event.

Traction control must be disabled at all times throughout the event.

### **2.2.3 Engine oil quick refill**

The use of the optional "oil quick filling kit" as shown in the catalogue is permitted, as long as the mounting is compliant with the Porsche AG's official mounting instructions. The hole in the engine lid necessary to fit the quick oil fill must be fully covered by clear heli tape. The use of the engine oil quick fill in pitlane during any Porsche Carrera Cup France event is prohibited.

## 2.3 Power transmission (gearbox/differential)

### 2.3.1 General description

Porsche six-speed sequential dog-type gearbox. Sealed (for warranty purposes only).

Gear ratios:

- |                        |       |             |
|------------------------|-------|-------------|
| ▪ Ring & pinion gear   | 15/23 | $i = 1.533$ |
| ▪ Final drive          | 16/39 | $i = 2.438$ |
| ▪ 1 <sup>st</sup> gear | 13/41 | $i = 3.154$ |
| ▪ 2 <sup>nd</sup> gear | 17/40 | $i = 2.353$ |
| ▪ 3 <sup>rd</sup> gear | 20/37 | $i = 1.850$ |
| ▪ 4 <sup>th</sup> gear | 24/36 | $i = 1.500$ |
| ▪ 5 <sup>th</sup> gear | 24/30 | $i = 1.250$ |
| ▪ 6 <sup>th</sup> gear | 28/30 | $i = 1.071$ |

Internal pressure-oil lubrication with active oil cooling by oil-water heat exchanger

Mechanical limited slip differential

Triple-disc sintered metal race clutch

Paddle shift with electronic shift barrel actuator

The gearboxes are sealed by Porsche AG prior to delivery.

Gearbox overhauled by the professional approved by Porsche France will be sealed prior to delivery, as proof of warranty only.

Teams are free to overhaul gearboxes and differentials themselves

### 2.3.2 Ramp breakover angle

The ramp breakover angle of the differential lock is 52° (traction) and 35° (overrun). The ramp angles are determined from the axis of rotation (Appendix 4). The number of friction plates and the assembly order shall correspond to the specification in the technical manual and must not be changed. The fitted friction plates must comply in terms of part number, allocation and specification (see parts catalogue).

### 2.3.3 Transmission emergency function

After the transmission emergency function has been switched on, the vehicle must immediately return to the pit lane. The vehicle is not allowed to leave the pit lane again until this function has been deactivated.

## 2.4 Lubrication system

### Engine lubricant:

- Mobil 1 ESP X3 0W-40 engine oil is compulsory.
- All additives are prohibited.

### Transmission lubricant:

- Mobilube 1SHC 75W-90 transmission oil is compulsory.
- All additives are prohibited.
- No less than the minimum quantity of transmission oil in the gearbox as specified in the manual must be used at all times during the event.

## 2.5 Brakes

It is not permitted to modify the car to endurance brake calipers, even if they might be listed in the parts catalogue.

### General description

Two independent brake circuits with brake pressure sensors for front and rear axle, adjustable by the driver via brake balance system. Derivative sensors & harness for retrofitting an ABS system.

- Racing brake pads
- Optimized brake ducts
- Ergonomic brake pedal positioning
- Derivative sensors & harness for retrofitting an ABS system

### Front axle:

- Six-piston aluminium monobloc racing brake calipers with "anti-knock-back" piston springs
- Ventilated 380 mm x 32 mm steel brake disc mounted on aluminium disc bells

### Rear axle:

- Four-piston aluminium monobloc racing brake calipers with "anti-knock-back" piston springs
- Ventilated 380 mm x 32 mm steel brake disc mounted on aluminium disc bells

The use of any system working like an ABS system is strictly prohibited. For easier handling and more versatile use of the cars beside the Porsche Carrera Cup France, it is allowed have the following parts of the ABS system offered by Porsche Motorsport still in the car during the official race meetings of the Series, as long as all components are fitted complying with the official Porsche mounting instructions:

- ABS adapter harness
- G sensor ABS and TC
- Hydraulic pump (electrically disconnected) with its bracket

The complete brake lines, their routing and all connections must at all times during an official race meeting of the PCCF remain original. At the Series Organiser discretion and when being asked, every competitor must remove also the allowed components.

## 2.6 Wheel suspension

- Racing shock absorbers, non-adjustable
- Forged control arms & top mounts
- Wheel hubs with center-lock wheel nut
- Double-blade-type adjustable anti-roll bar
- Tire pressure monitoring system

### 2.6.1 General description front axle

Double wishbone front suspension, adjustable ride-height, camber and toe  
Electric power steering with manual function to ease car maneuvering

### 2.6.2 General description rear axle

- Multilink rear suspension, adjustable ride-height, camber and toe
- Motorsport driveshafts optimized for reliability and durability

### 2.6.3 Allowed adjustments

The suspension is allowed to be modified within the scope of the specified setting range. All genuine parts must be retained.

The maximum permissible combined thickness of the camber spacer are specific to each event:

Racetrack	Barcelona, Magny-Cours	Red Bull Ring, Paul Ricard	Le Mans, Monza
Front axle	20.0 mm	19.0 mm	18.0 mm
Rear axle	15.0 mm	13.0 mm	11.5 mm

The non-removable spacer (part number 9F1.505.184) of the rear lower control arm will be included when determining the combined thickness of the camber spacer washers.

A change to the maximum permissible combined thickness of the spacer washers in the front and rear axle control arms can be announced by Stewards' bulletin at any time before or during any event.

It is allowed to fix the camber shims with aluminium tape.

All bearing points of the front and rear control arms must be left in the position in which they are delivered. The adjustment of the excentre screw at the front upper control arm mounting bracket, within its specified setting range, is permitted.

### 2.6.4 Anti-roll bars

The anti-roll bars are only permitted to be unhooked provided that one coupling rod of the respective rollbar is completely removed. Only the respective setting options given in the manual are permitted to be used.

The axial clearance of the anti-roll bars on the front and rear axles must be below 1.0mm. Designated shims shown in the spare parts catalogue are permitted to be used to compensate for the axial clearance.

### 2.6.5 Shock absorbers/springs

Only the factory-installed type shock absorbers and springs in their original condition are allowed to be used. The original delivery condition of the bump stops of the front and rear dampers must not be modified in any way.

## 2.7 Wheels (flange + rim) and tyres

### 2.7.1 General description

Single-piece light-alloy rims according to Porsche specification and design with centre lock.

#### **Front axle:** 12Jx18 ET23.5mm

Treaded Michelin transportation tires; tire size: 30/65-18

#### **Rear axle:** 13Jx18 ET44.5mm

Treaded Michelin transportation tires; tire size: 31/71-18

### 2.7.2 Wheels

The use of any other wheels than the originally specified wheels is prohibited.

All wheels must be fitted with original tyre pressure and temperature sensors.

Only the use of valve caps mentioned in the respective spare parts catalogue is allowed and strictly enforced for all races.

The rims are allowed to be painted. It is prohibited to paint or treat any functional surfaces (rim bed, contact area of wheel nut, mounting surface of the wheel). Rims may be repaired. The friction strips on the inside of the rim must stay functional and must not be treated in any way.

### **2.7.3 Tyres**

Only the version of Michelin tyres approved for the Series with the following specification and supplied by the official supplier announced by the Series Organiser is allowed to be used for the duration of the events and the official tests.

#### **Slick tyres:**

- Front: 30/65 R 18 Porsche Cup N3
- Rear: 31/71 R 18 Porsche Cup N3R

#### **Rain tyres:**

- Front: 30/65 R 18 P2L
- Rear: 31/71 R 18 P2L

Tyres are provided by Michelin on each meeting. Entrants must use tyres coming from the official supplier which is Auvergne Pneumatique Racing.

Porsche AG suggests that all competitors follow the recommendations and instructions of Michelin regarding tyre pressures and set-up. Only atmospheric air is allowed to be used to inflate the tyres.

It is not permitted to rotate the tyres on the rims. The identification barcode of each slick tyre must be visible from the external side of the tire when it is mounted on the car.

Should the tyre manufacturer prescribe a rotational direction for its tyres, then any departure from the manufacturer's recommendation is prohibited, the barcode location doesn't matter anymore.

The Series organiser reserves the right to allocate the tyres randomly to each entrant.

### **2.7.4 Tyre marking**

Throughout these regulations any reference to the marking of tyres includes the procedure of electronically scanning and recording the individual bar codes of tyres.

For each meeting of the Porsche Carrera Cup France: a maximum number of 8 slick tyres and 8 rain tyres for each vehicle (starting number) can be marked by the Technical Scrutineers.

For the entire 2023 season, 3 additional tyres per car (race number) may be registered as "jokers". The technical scrutineers will register those tires only after the end of the qualifying session and up to a maximum of one hour before the start of Race 1. A maximum of two (2) joker tires may then be used for all races of each meeting. These tires can be slick or rain tyres.

Every slick or rain tyres must be registered by the Technical Scrutineers before using it on track (except for rain tyres during the free practices).

### **2.7.5 Tyre ordering**

The tyres for the respective event must be ordered from Michelin in good time – at least ten working days before the start (=set-up day) of the race event – using the official form.

Tyre mounting operations will take place during a specific period of time to be announced by the Series organizer.

### **2.7.6 Free practice**

For the free practice sessions of the initial event of season, it is allowed to register a maximum of 8 additional slick tyres per entrant. These tyres can be used again only in the free practice sessions of the next meetings. The rain tyres quantity is not limited

From the second event of his season, each entrant must only use its previously registered slick tyres or joker tyres during the free practice sessions. The rain tyres are not limited

### **2.7.7 Qualifying and race**

Only the tyres marked for the relevant race event are allowed to be used for the respective qualifying and race. Only correspondingly marked tyres are allowed to be taken into the pit lane for qualifying and races of the event.

### **2.7.8 Guest drivers**

Guest drivers may register a maximum of 8 slick tyres and 8 rain tyres per event.

For the free practice sessions of the first meeting where a guest driver with a start number which is the first time the particular start number is entered into the 2023 season of the Porsche Carrera Cup France is entering, a maximum of 8 additional slick tyres can be used. For the meeting onwards, these slicks tyres may be run only in free practice sessions. Besides, only previously registered tyres will be allowed in these next free practice sessions. Nevertheless, the rain tyres are not limited for the free practice sessions.

At every event a Guest driver is participating, he will be able to register 1 additional "joker". It can be either slick or rain. A transfer of unused joker tyre to following event is not permitted.

### **2.7.9 Substitute drivers**

As tyres are allocated to a start number and not to a driver, the tyre rule for already entered start numbers applies.

### **2.7.10 Tyre damage**

Brand new tyres with damages can be replaced with the Technical Manager of the Series and Michelin's approval. In this case, the marking will be transferred by the Technical Scrutineers.

### **2.7.11 Treatment**

Any chemical, mechanical or thermal treatment of the tyres is prohibited. The mechanical removal of rubber abrasion and stones is permitted. The usage of heatguns or any similar device of any kind to help the removal of rubber abrasion and stones ("tyre scrapping") is prohibited. Cleaning of the rims is allowed.

The use of heated covers, materials or other means that change the temperature of the tyres is prohibited for the entire duration of an event.

From the time of the pre-start until the end of the session, the event approved tyres are not allowed to be covered. This applies for slick as well as rain tyres.

### **2.7.12 Tyre logs**

The entrants will have to fill a marking list in paper format, which contains the barcodes of the tyres they want to register for the ongoing event and return it to the Technical Scrutineers at least 1 hour before the first session where these tyres can be used.

All barcodes of the marked tyres will be scanned and recorded in lists by the Technical Scrutineers, the so-called tyre logs, which will be handed over to the entrants. The entrants can access these tyre logs to check if the registered barcodes are the same than the paper-format list they returned.

No tyre is allowed to be used if it is not listed on the tyre log of the Technical Scrutineers before the respective session. If joker tyres are to be used, they must be added to the tyre logs. The updated tyre logs are also subject to the aforementioned procedure.



### 2.7.13 Collective test days

The tyres used during the collective test days will not be marked.

The number of tyres will not be limited.

### 2.7.14 Recap of tyres regulations:

	<b>First meeting</b> <i>(first meeting of the season for a regular entrant or first time a Guest entrant is entering a meeting)</i>	<b>Meetings onwards</b> <i>(from the second meeting where a driver is entering till the end of the season)</i>
<b>Free Practice</b>	Qty max. per entrant: <ul style="list-style-type: none"><li>▪ 8 slicks</li></ul> -> Can be used again only during the free practice sessions of next meetings	Registered slicks tyres from previous meetings of the season + joker tyres Rain tyres are not limited
<b>Qualifying/Race</b>	Qty max. per entrant: <ul style="list-style-type: none"><li>▪ 8 slicks tyres and 8 rain tyres + jokers</li></ul>	
<b>Joker Tyres</b>	Qty max. on the whole season for each regular entrant: <ul style="list-style-type: none"><li>▪ 3 tyres (slicks or rain)</li></ul> Qty max. per meeting for a Guest entrant: <ul style="list-style-type: none"><li>▪ 1 tyre (slick or rain)</li></ul> -> The « joker tyres » will be registered between the end of Qualifying and the beginning of Race 1. 2 jokers tyres maximum can be used for all the races of an event.	

### 2.7.15 Road to and from the pit lane

The route to and from the pit lane for the free practice may be taken on rain tyres. The route to and from the pit lane for qualifying session may be taken on marked rain tyres.

## 2.8 Body and dimensions

### 2.8.1 General description

Lightweight bodywork featuring intelligent aluminum-steel composite design

Integrated (welded) roll cage, in compliance with FIA regulations (permitted for co-driver usage on circuit events)

Front cover with integrated quick-release fasteners; cooler exit-air duct and central air intake for cockpit

Removable rescue hatch in compliance with the latest FIA safety regulations

Mounting point for lifting device

Fenders with extensions

Widened front bumper with spoiler lip

Rear bodywork with integrated rain light, in compliance with FIA regulations

#### **Lightweight exterior:**

Carbon-fiber-reinforced plastic doors with quick release push button

Carbon-fiber-reinforced plastic rear engine lid with quick release fasteners, removable

Carbon-fiber-reinforced plastic adjustable rear wing with "swan neck" (11 positions)

Polycarbonate door windows and rear side windows with ventilation openings

Polycarbonate windows with hard coating

Rear underfloor with NACA ducts for brake and driveshaft and shift barrel actuator cooling

#### **Modified 911 cockpit:**

Carbon-fiber reinforced plastic interior trim panels

Ergonomic digital touch panel with multi-color backlight aligned towards driver

Multifunctional carbon-fiber reinforced plastic motorsport steering wheel with quick release coupling, shift paddles and illuminated push buttons

Adjustable steering column with steering angle sensor

Safety nets (center and driver's side) in accordance with latest FIA safety regulations

Optimized cockpit ventilation featuring airflow directed at driver

Race bucket seat in accordance with FIA Standard 8862/2009:

    Infinite longitudinal adjustment,

    Two positions for height and inclination adjustment

    Padding system in three sizes to adapt seat to individual drivers (delivered with size M)

    Preparation for seat ventilation

Six-point racing safety harness

110 liter fuel cell (FT3 safety fuel cell) and dry break couplings for fueling and draining using a fully enclosed system

Fuel-Cut-Off" safety valve in accordance with FIA regulations

Built-in air jack system (three jacks) with valve mountable on both sides of the car

#### **Color:**

Water-based paint

Exterior: GT silver metallic (M7Z)

Interior: GT silver metallic (M7Z), without clear lacquer finish

Rims: Platinum semi-matt (OB5)

Rear wing in naked carbon

### **2.8.2 Overall vehicle dimensions and overhangs:**

Total length: 4,585 mm (180.51 inch)

The track width of the front axle measured at the center of wheel hub plugs is 1885 mm +/- 10mm.

The track width of the rear axle measured at the center of wheel hub plugs is 1855 mm +/- 10mm.

The front overhang is 1,036 ±15.0mm, measured from the middle of the wheel of the front axle to the leading edge of the vehicle (first point in the direction of the longitudinal axis, incl. front lip).

The rear overhang is 1,081 ±15.0mm mm measured from the middle of the wheel of the rear axle to the rear edge of the vehicle (last point in the direction of the longitudinal axis, including the exhaust, rear wing excluded).

The wheelbase on the left and right sides of the vehicle must be 2,468mm +/- 15 mm. The measuring points are the centers of the wheel hubs.

### **2.8.3 External bodywork (including windows)**

The delivery status of the bodywork has to be preserved.

### **2.8.4 Windscreen**

As a replacement to the original part, a heated windscreen as shown in the spare parts catalogue is permitted. The windscreen is permitted to be connected to the electrical system of the car and the heating function is permitted to be used.

To protect the windscreen and as a safety measure, 'tear-off' screens are allowed to be attached to the windscreen. Fitting will be checked during technical scrutineering and must be removed where applicable on request of the Technical Scrutineers.

### **2.8.5 Side and rear windows**

Only the genuine Porsche 911 GT3 Cup side and rear windows in their original version are permissible.

Additionally, the rear window must remain fixed with the original type of fixing at all times.

## **2.8.6 Cockpit**

### **Seat**

The adaptation of the seat by the addition of original Sabelt seat padding shown in green and blue in Attachment 6 is permitted.

Each padding shape may only be used in the specific and correct location and direction as shown in Attachment 6.

Additional padding at the head rest can only be added in accordance with the following conditions and the Technical Scrutineers' discretion:

- The foam used for the padding must be the same material as the one used on the head rest by the seat manufacturer.
- The padding must be properly fixed to the seat.

Any addition or removal of material below the surface shown in black is forbidden.

A foamed seat insert, according to FIA Appendix J, Article 253-16, may be used as long as the insert is made of fireproof material, coloured in black. The use or change is subject to approval by the Series Organiser/Technical Scrutineers.

The original mounting (seat rail and bracket) must be retained and must not be modified.

The provisions of FIA International Sporting Code Appendix J Article 253 - 16 must be complied with at all times.

### **Ventilation in the passenger compartment**

Only the factory-fitted ventilation pipe (on the front opening hood) is permissible for cockpit ventilation. The ventilation of the windscreen must not be affected. For additional ventilation of the passenger compartment only the existing original ventilation openings in the rear back windows are permissible.

The ventilation/demisting front windscreen system must remain operational at any time during the event.

### **Safety nets**

Additionally, every car must be equipped with the after sales safety nets as specified in the valid spare parts catalogue and mounted complying with the Porsche AG mounting instructions.

## **2.8.7 Additional roof hatch accessories**

The car has a roof hatch (to facilitate Driver extraction) which is connected to the roof via 7 livelocks and which must be accessible at all times (no foiling or painting of live locks is permitted).

## **2.8.8 Ground clearance of vehicle**

The minimum ground clearance of the ready-to-drive vehicle (with the driver in the vehicle and slick tyres in compliance with Article 2.7, at 2.0 bar  $\pm$ 0.1 bar air pressure) must not be less than the specified dimension, as measured at the specified measuring points, at any time during the race event.

For the entire duration of the race event the ground clearance of the front axle is to be a minimum of 72 mm and the clearance at the rear axle a minimum of 106 mm.

The measuring points (see Attachment 5) at the front axle are the mounting bolts of the cross member/bodywork in relation to the reference surface and the machined rear surface in the direction of travel on the side section of the rear axle in relation to the reference surface. The ground clearance is allowed to be changed within the existing adjustment range.

The minimum ground clearance for the front axle must be achieved with the reinforcement sleeves 9F1.407.371 fitted on the subframe, as well as undamaged and unmodified mounting bolts (part number WHT.008.757). The height of an undamaged and unmodified mounting bolt head will be defined as 11.8mm. If the height of the mounting bolt heads

fitted to the car during the ground clearance measurement measures less than 11.8mm, the difference will be taken into account.

Any modification of the ride height using the front spring rests is strictly forbidden during all qualifying sessions and also between these sessions in the case of qualifications with break in the pit lane.

### **2.8.9 Measuring location and method**

The measurement of the minimum ground clearance is conducted on the measuring plate in the technical scrutineering area. The measuring plate is available to the participating teams to check the minimum ground clearance at all times in consultation with the Technical Scrutineers.

The minimum ground clearance is checked using an appropriate height gauge for the axle to be measured in each case. The measurement is checked with the ready-to-drive car including the Driver on board, standing on the measuring plate. If the measuring gauges can be correctly accessed under the measuring points described above, the requirement to comply with the minimum ride height is satisfied.

The Technical Scrutineers may at any time in their absolute discretion check the ground clearance measurement with any set of tyres allocated to the respective start number used during the session that the check is performed during or after. The Technical Scrutineers may also use instruments such as calipers or depth gauges to determine the vehicle height. Any measuring tolerances will be taken into account by the Technical Scrutineers.

With the team's and technical scrutineer's mutual agreement, the ride height can be measured with a member of the team (instead of the driver), whose weight must be greater or equal than the pilot's weight recorded at the end of the corresponding session.

### **2.8.10 Failure to reach minimum height**

Failure to reach the minimum height will be reported to the Stewards of the Event and penalized.

## **2.9 Aerodynamic devices**

The original position of the wing section is allowed to be changed within the specified scope for adjustment.

Furthermore, entrants are allowed to tape over the full area of the headlight lenses with transparent Heli tape, without thereby taping over a slot in the bodywork.

Apart from the above, taping over of any slots in the bodywork, wings or other permanent parts, joints and openings is not allowed.

## **2.10 Electrical equipment**

### **General description:**

- 10.3" Porsche color
- Display Porsche logger
- Electrical system control unit
- Fire extinguishing system (extinguishing agent: gas)
- Lightweight 12 V, 60 Ah battery (LiFePO4) leak-proof, installed in co-driver's footwell
- Alternator 175 A
- Single-arm windscreen wiper with direct drive (intermittent and continuous operation)
- Three additional center console switches for additional power consumers
- Data connection (data logger, video system)

### **Lighting system:**

- Main headlight
- Daytime running light

- Rear lighting system and rain light in compliance with the latest FIA Homologation Regulation

Optionally, the usage of the following electrical equipment is permitted:

- AS sensor GPS
- Harness USB
- RLU rugged USB memory
- MTH000116A : charging cable (installation according to latest mounting instructions)

From the "pre-grid" to the end of the "Parc Fermé" during qualifying and racing, only the Series Organiser and personnel nominated by the Series Organiser are allowed to connect laptops/computers to the vehicles. For the same period, no external connection (also wireless) may be made between the car and any external equipment other than the cars equipment to read from the antennas of the tyre pressure monitoring system. It is not permitted at any time for any competitor to read any sensors with any equipment, which are not allocated to the competitor's own team. Any breach of this regulation may result in the vehicle being disqualified from qualifying or racing.

The front wiping system must be conserved in its original state and must be operational at any time during the meeting.

### **2.10.1 Data transfer**

The use of other radio-based information transmission in the vehicle (e. g. telemetry) is forbidden, the only exception is the usage of the built-in tyre pressure monitoring system, which uses radio transmission for its functionality.

### **2.10.2 Radio system**

The installation and use of a radio system is mandatory.

The choice of hardware for radio reception from the "Earplug" port to the driver is optional but must be checked and approved by the Technical Scrutineers. When mounting fixed speakers in the driver's helmet, the FIA helmet regulations must be strictly observed. In the case of any ambiguity, the driver/ entrant must produce proof that the components used are suitable for use in the vehicle (fire prevention, etc.).

Modifications to the system are not permitted. Extra equipment must only be attached to the radio system by the Porsche Carrera Cup France Organisation. The Series Organiser has the right to listen to voice radio communication between the team and the driver separately.

The Series Organiser may authorize that a separate radio loom can be carried in the vehicle, providing it is completely electrically disconnected from the vehicle and does not interfere with or alter any function of the vehicle or the official radio system. The installation of a separate radio loom must be approved by the Technical Scrutineers, considering those points.

### **2.10.3 Data recording**

Use of the factory-fitted data recording system manufactured by COSWORTH is compulsory. The COSWORTH system is assigned to the vehicle chassis number and must not be exchanged. Only the setups approved by Porsche are allowed to be used for the duration of the event.

Only the infrared pit wall beacon signal provided by the Series Organiser may be used to create lap times in the recorded data.

All recorded data relating to the free practice, qualifying or race must be made available to the Technical Scrutineers or the Series Organiser.

All laptop connection by the teams to the vehicles is forbidden during qualification sessions and races, from the pre-grid area to the Parc Fermé.

Directly after parking in Parc Fermé, the Driver is allowed to remove the optional RLU RUGGED USB MEMORY from his car. The removal by any other person and/or at a later time before the end of Parc Fermé is prohibited.

Any additional electrical connection to the vehicle wiring harness is not allowed. Installations set up by the Series Organiser are exceptions to this rule.

#### 2.10.4 Timing Transponder

Only the transponder provided by the Series organizer must be used during a meeting. Exception made if the competitor already has a transponder identical in all respects to that of the organizer, in which case he must communicate the serial number of his equipment to the organization before the start of the meeting.

#### 2.10.5 Other radio-based or electronic devices

The use of other radio-based or electronic devices in the vehicle (e. g. telemetry, mobile phones) is prohibited. The only exception is the usage of the built-in tyre pressure monitoring system, which uses radio transmission for its functionality.

The Porsche Mobil1 Supercup transponder (together with its wiring loom) as well as the ADR system can be carried over on the vehicle, as shown below. Both transponder and ADR must though be electrically disconnected.

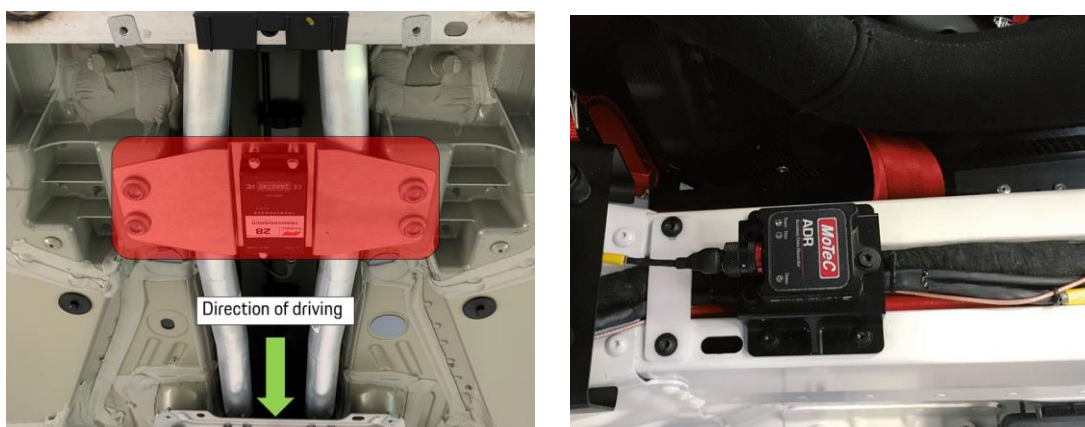

#### 2.10.6 Cameras

The use of on-board cameras is mandatory. Mounting and fasteners must be checked by the Technical Scrutineer.

Recorded images must remain at the disposal of the organisers and race management throughout the duration of the season. The use of rights of all images belongs to Porsche France. Recorded images can be used in private but should not be forwarded to third parties.

Between the starting light and the end of Parc Fermé of each session, the memory card/USB stick recording the datas of the camera shall be taken out of the car only by a 2023 Porsche Carrera Cup France organisation member. A non-respect of this rule can lead to the entrant and his car to be excluded from the event.

It is mandatory that your memory cards are very easily identifiable. It is mandatory to affix on the memory cards at least the race number of the car to which the memory card corresponds to this in order to facilitate the collection and the identification of the cameras on board during a race incident. Cameras must be calibrated with the exact date and time. The memory card used should only contain the video files of the relevant meeting, to the exclusion of any other files. Any competitor unable to make available all or part of the onboard images (lack of files, SD card, camera malfunction ...) can be penalized.

### 2.11 Miscellaneous

#### 2.11.1 Seals

The following seals are affixed at the workshop:

- **Engine:**
  - Valve cover, left (1x)
  - Valve cover, right (1x)

Oil pump bottom (1x)

Engine control unit: Connector for control unit wiring harness (2x)

If seals and marks are applied to the vehicle by the Technical Scrutineers or Porsche, these must not be damaged, changed or reproduced. If one or more damaged or missing seals or markings are discovered, the vehicle can be disqualified from the event.

If one of the seals on the engine control unit is opened to allow welding work to be carried out, the control unit must then be taken to the Technical Scrutineers for an additional inspection and then be resealed, without being requested to do so. The removed seal(s) must be handed over to the Technical Scrutineers.

Seals that have fallen off during the race or are damaged must be notified to the Technical Scrutineers in writing no later than one hour after closure of the "Parc Fermé".

### **2.11.2 Electronic car configuration**

Throughout each event, the car must be run with the following configuration settings:

- Traction control and ABS variant "Basis" and the logged channel "log\_car\_variant" with the value "1" visible in the display
- Exhaust system setting – visible in Racecon – in accordance with the event exhaust configuration:  
Running with pre-silencers: CW\_silence=1 and B\_silence\_pt=1  
Running without pre-silencers: CW\_silence=0 and B\_silence\_pt=0

### **2.11.3 Additional fixation rear brake air duct**

It is permitted to secure the two halves of the air duct element (part numbers 9F1.615.457 and 9F1.615.458) or (9F1.615.447 and 9F1.615.448), using a maximum of 3 cable ties around each element, to prevent their separation.

#### **Notes**

In case of disagreement regarding the interpretation of this regulation, the decision of the Series Organiser shall be final regarding any interpretation of these Regulations.

In addition, the FFSA's sports disciplinary bodies are competent.

## Part 3 – Appendix

### Appendix 1 – 2023 overall and badge Regulations\*

It is mandatory to affix those badges to the drivers' racing suits as prescribed in this regulation for the entire event. Embroideries of the official partners of the Porsche Carrera Cup France will be automatically affix on racing suits at the locations specified in this regulation.

This rule also applies for guest entrants in Porsche Carrera Cup France. Guest and substitute drivers must affix these embroideries on their racing suit.

Please note that for the embroidery/affixing of badges to racing overalls (FIA Standard 8856-2000) the following rules applies:

- Embroidery sewn directly onto the overall shall be stitched onto the outermost layer only. Backing material of badges shall be fireproof and in conformity with the standard ISO 15025 (NOMEX).
- The backing used for affixing the badge to the overalls shall be fireproof and in conformity with the standard ISO 15025 (NOMEX). Embroidery thread used to affix badges shall be fireproof and in conformity with the standard ISO 15025 (NOMEX).
- When affixing badges and signs to overalls, heat-bonding shall not be used.
- Any embroidery or affixing of badges not complying with these conditions will result in the cancellation of the homologation of the overalls concerned.

Please use the following positions for the affixing of obligatory badges:

- A) Porsche Carrera Cup France Logo (Width 130mm)
- B) Mobil 1 Logo (Width 130mm)
- C) Michelin Logo
- D) Reservation Porsche



\*Subject to amendments.



## Appendix 2 - 2023 Sticker Regulations\*

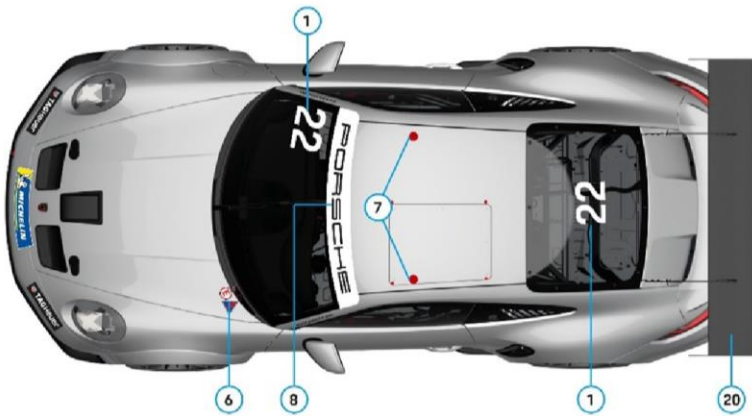
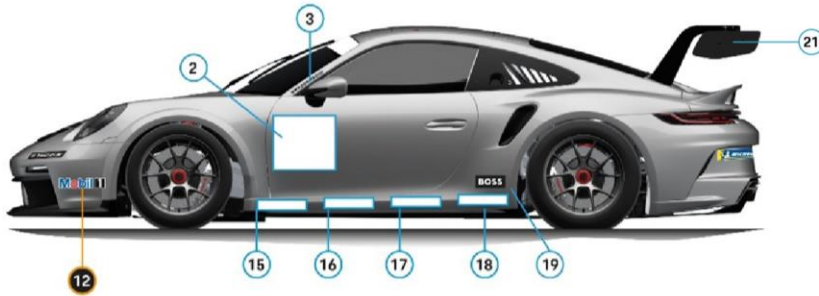
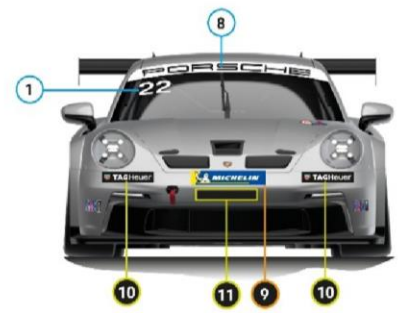
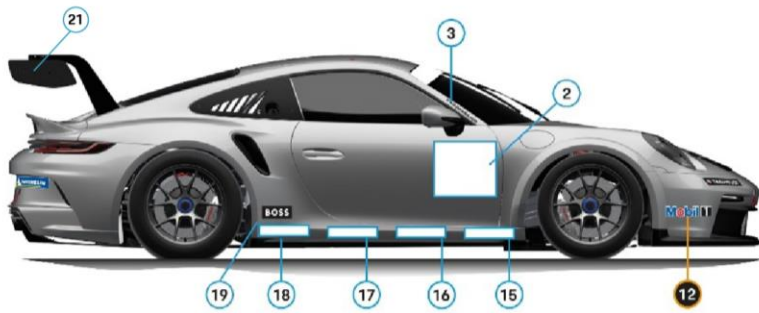

**PORSCHE**  
**MOTORSPORT**  
**ONE-MAKE SERIES**

### Sticker Regulation 2022

- All Carrera Cups; Challenges and Trophies as per individual contract
- All Carrera Cups

Number	Quantity	Size (in mm)	Colour	Logo/Symbol	Placement
1	2	Name: 100 height Number: 200 height	White	Driver's name + Starting number	Windscreen top right + rear window top center
2	2	360 x 308	White with white frame	Plate + Starting number	Left and right door
3	2	395,8 x 35,8	Black or white	www.porsche.fr	A-pillar left and right
4	1	526 x 32	Black or white	PORSCHE lettering	Rear lid
5	1	256,5 x 40	Black or white	GT3 Cup	Rear lid
6	1	207 x 107	Red-black	Flash for current interrupter + Letter "E" for extinguisher	Front bonnet left

7	2		Red with white outline	Mounting of integral two-mount rescue device	Roof
8	1	1244,5 x 133,7	TAG Heuer original colours with black background	TAG Heuer+ 75 <sup>th</sup> Birthday logo	Windscreen top
9	1	557 x 120	MICHELIN original colours	Michelin	Front bumper
10	2	255 x 50	TAG Heuer original colours with black background	TAG Heuer	Area above daytime running light unit
11	2			Reservation Porsche	Front bumper
12	2	280 x 66	Mobil 1 original colours	Mobil 1	Front bumper, left and right
13	1	280 x 66	Mobil 1 original colours	Mobil 1	Rear bumper
14	2	280 x 66	Michelin original colours	Michelin	Rear bumper, left and right
15	2		Du Sport et Plus original colours	Du Sport et Plus	Side sill, left and right
16				Reservation Porsche	Side sill, left and right
17	2		Black or white	Instagram Porsche Carrera Cup France	Side sill, left and right
18	2		Flat 6 original colours	Flat 6	Side sill, left and right
19	2	210 x 77	White on black	BOSS	Side sill, left and right
20	1		Black or white	Porsche Logotype	Rear spoiler
21	1		Black or White	75 Logo Anniversary	Stop plate rear wing

**Please note:**

The mandatory stickers are to be obtained only from Porsche Carrera Cup France.

The minimum space between stickers must be 30mm.

The sticker positions 1-21 are strictly reserved for the Series Organizer.

If position 11 and 16 are not occupied by Porsche Carrera Cup France, they shall be available for team identification purposes upon written request to Porsche Carrera Cup France until availability is revoked.

All positions in direct visibility of the on-board cameras in the interior and exterior areas of the racing car are reserved for Porsche Carrera Cup France and cannot be used by the Competitors (unless previously authorised in writing).

Only the logo of the team (painted in white) can be written on the front central air entrance.

Usage of current or historic livery of Porsche Motorsport works racing vehicles is reserved for Porsche AG and the Porsche Carrera Cup France.

**Exclusivity rule:**

Advertising of Competitor partners that compete with partners of Porsche AG, Porsche Carrera Cup France and/or cooperation partners shall be prohibited.

In regards to, the exclusivity of the partners of Porsche AG following rules apply (the exclusivity rule refers to the industry sector or to the product range of a manufacturer):

- Mobil 1 is the exclusive partner of Porsche AG for lubricants, thus prohibiting teams to communicate or advertise for companies or products that are rivals of Mobil 1 lubricants.

For the area of fuels, Competitors are allowed to communicate or advertise for other companies under the following conditions and subject to final approval of Porsche Carrera Cup France Organisation:

- The product brand "fuel" has to be clearly distinguishable from the company brand, e.g. "V-Power" or "Ultimate".
- A maximum of one team with 4 race cars may communicate or advertise for one fuel brand. The date of the contract signing is pivotal.

Any fuel team sponsorship is required to be approved by Dr. Ing. h.c. F. Porsche AG prior to signature of any agreement between a Competitor and a potential fuel sponsor.

- Michelin is the exclusive partner of the Porsche Carrera Cup France. Therefore, it is forbidden to teams to communicate or advertise for companies or products that are competitors of Michelin.
- Hugo Boss is the exclusive partner of the Porsche Carrera Cup France regarding apparel and team wear. The exclusivity is limited to the relationship with Porsche, not to the advertising space on the race cars, which is available to competitors. This means, teams can still show their own apparel partner on the car, as long as the Hugo Boss logo is on the car as well.
- Tag Heuer is the exclusive partner of the Porsche Carrera Cup France for watches and jewelry. The exclusivity is limited to the relationship with Porsche, not to the advertising space on the race cars, which is available to competitors. This means, teams can still show their own clockmaker, time clocks and others time equipment on the car as long as the Tag Heuer logo is on the car as well.

There is no exception for partners of exclusivity.

For any questions or additional information, please contact Porsche Carrera Cup France.

### Appendix 3 – Ballast weights

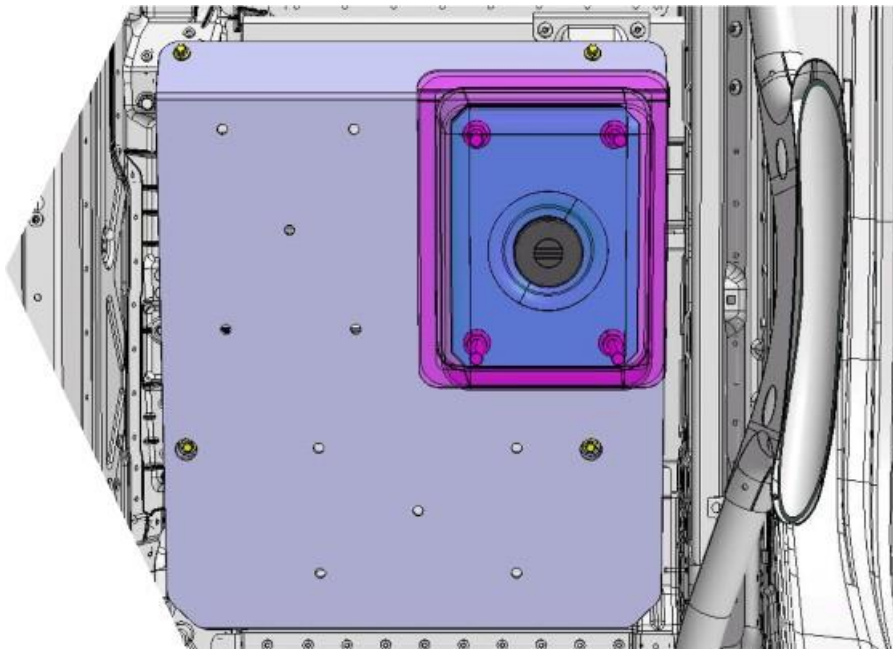

### Appendix 4 - Differential lock, ramp angle

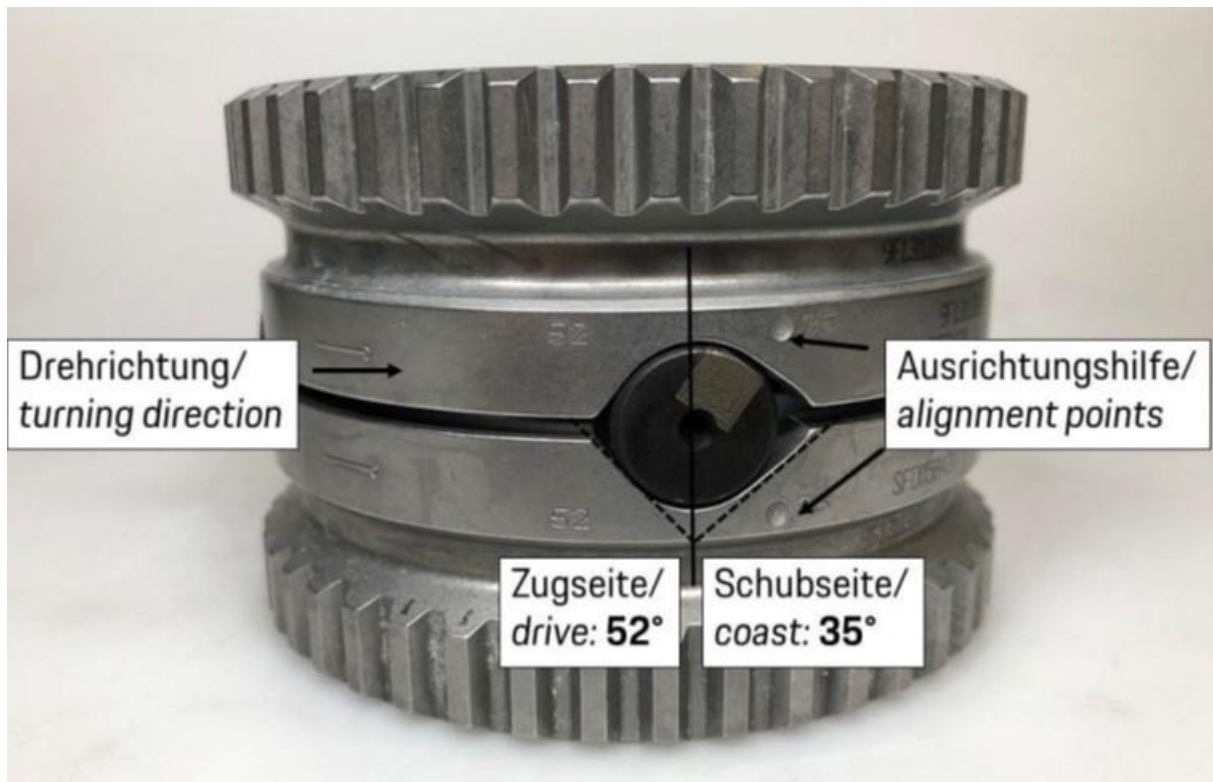

## Appendix 5 - Minimum ground clearance, rear and front axle

### Positionen Fahrhöhenmesspunkte/ ride height measuring positions

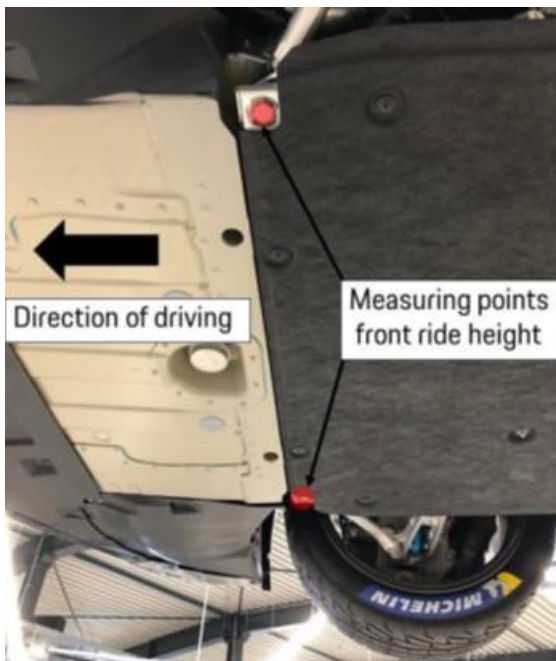
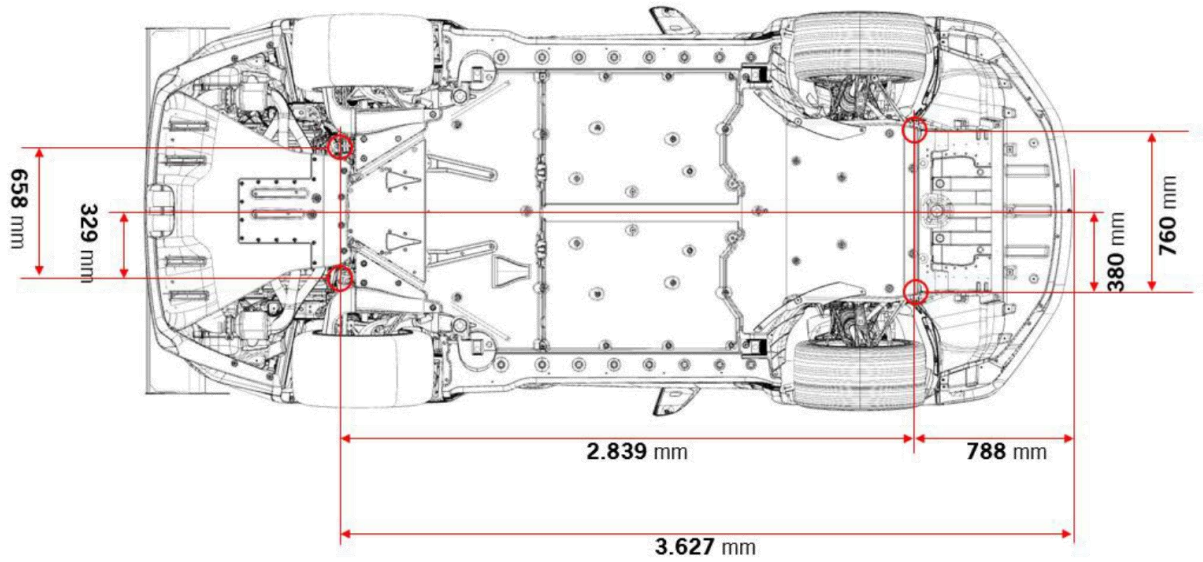

## Appendix 6 – Seat padding

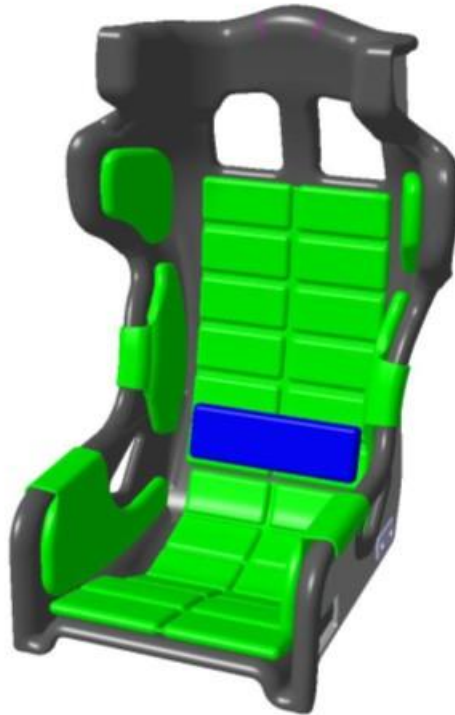

## Appendix 7 – Part number reference table

Part	Part number	Alternative P/N (old version)
Additional ballast 2kg (6mm)	9F1801141	991.504.848.00 and 997.504.484.00
Additional ballast 3.5kg (10mm)	9F1801141A	991.504.848.01 and 997.504.848.01
Additional ballast 6.8kg (20mm)	9F1801141B	991.504.848.02 and 997.504.848.02
Ballast cover	9F1801575	991.504.865.9B
Cover nut	WHS001903	991.504.852.9B
Left wheel nut	9F1412157	997.331.307.9A
Right wheel nut	9F1412158	997.331.308.9A

## Appendix 8 - Table of Penalty Guidelines

OFFENCE	FREE PRACTICE	QUALIFYING	RACE	POINTS
<b>GENERAL</b>				
Not attending or late to Drivers' Briefing	EUR 300 ex-VAT minimum (EUR 500 ex-VAT minimum subsequent times). Driver must be briefed before going on track.			1
Disobeyed marshals / officials' instructions	EUR 500 ex-VAT + deletion of lap times		Drive-through penalty	1-2
Did not respect the 3-minute signal			5 - 10 seconds time penalty	0
Teams did not clear grid before 1-minute signal			5 - 10 seconds time penalty	0
Not wearing Michelin cap at podium			EUR 2,500 ex-VAT	0
Display of unauthorised sponsorship badges at podium			EUR 2,500 ex-VAT	0
Failure to attend post session driver weighing	Deletion of all lap times		Disqualification	0
OFFENCE	FREE PRACTICE	QUALIFYING	RACE	POINTS
<b>TECHNICAL</b>				
Non-compliance with scrutineering schedules	Financial penalty: 110€ ex-VAT minimum			0
Underweight		Deletion of all lap times	Disqualification	0
Contravention of regulations regarding wheels & tyres	Deletion of all lap times		Disqualification	0
<b>PIT</b>				
Reversed car under own power in pit lane	Drop of 5 grid positions		Drive-through penalty	2
Speed offence in the pitlane	Fine EUR 50 ex-VAT per kph	Drop of 3/5 grid positions	10 seconds time penalty or Drive-through penalty	1-2
Crossing white line at pit exit	Drive-through penalty in session or Drop of 3/5 grid positions		10 seconds time penalty or Drive-through penalty	1-2
Breach of Parc Fermé regulations		Deletion of all lap times	Disqualification	0

OFFENCE	FREE PRACTICE	QUALIFYING	RACE	POINTS
<b>START</b>				
Unauthorised practice starts	Drop of 3/5 grid positions		Drive-through penalty	1
False start			5-10 seconds time penalty	1-2
Overtook before the re-start of the race (Safety Car)			5-10 seconds time penalty or Drive-through penalty	1-2
<b>FLAGS</b>				
Did not slow down under Yellow flag	Drop of 3-5 grid positions		10 seconds time penalty or Drive-through penalty	1-2
Did not comply with Blue flag/Impeding		Drop of 3/5 grid positions	10 seconds time penalty or Drive-through penalty	1-2
Overtook under Yellow flag	Drop of 5/10 grid positions		10 seconds time penalty or Drive-through penalty	1-3
Failed to respect Black & Orange flag	Deletion of all lap times		Disqualification	2
Did not comply with Red flag	Deletion of all lap times		Disqualification	2-4
Passed Chequered flag more than once	EUR 500 ex-VAT fine or Drop of 3/5 grid positions		EUR 500 ex-VAT fine or Drop of 3/5 grid positions	1-2
OFFENCE	FREE PRACTICE	QUALIFYING	RACE	POINTS
<b>DRIVING STANDARDS</b>				
Caused a collision	Reprimand and/or Drop of 3/5 grid position		5 or 10-seconds time penalty or Drive-through or Stop-and go (or drop of grid positions if the driver did not finish the race)	1-3
Forcing another Driver off the track	Reprimand or Drop of 3/5 grid position		5 or 10-seconds time penalty or Drive-through or Stop-and go (or drop of grid positions if the driver did not finish the race)	1-3
Overtook during Safety Car operation			5 or 10-seconds time penalty or Drive-through	1-3
Driving unnecessarily slowly, erratically or in a manner which could be deemed potentially dangerous to other Drivers	Reprimand or Drop of 3/5 grid positions		5 or 10-seconds time penalty or Drive-through or Stop-and- go	1-3



OFFENCE	FREE PRACTICE	QUALIFYING	RACE	POINTS
Impeding another car	Reprimand	Drop of 3 /5 grid places	5 or 10-seconds time penalty or Drive- through	1-3
Left track and did not re-join at the same place or rejoined in an unsafe manner	Reprimand or Drop of 3/5 grid positions		5/10 seconds time penalty or Drive- through or Stop-and- go	1-3
Exceeded Track Limits	Deletion of relevant lap times and Drive-through in session, Drive-through or Drop of 3 grid positions for repeat offences		5/10 seconds time penalty for repeat offences. Drive-through penalty for continued offences	1-2
Gaining an unfair advantage (e.g. by overtaking off track without returning the position)	Loss of relevant lap time		3/5 seconds time penalty	1-2

## Appendix 9 – Contacts

### **Porsche France:**

#### **Christophe Sevens**

Product & Motorsport Manager  
25/29, quai Aulagnier  
92600 Asnières-sur-Seine  
Tél : + 33 (0) 6 73 89 87 95  
Mail : [crisophe.servens@porsche.fr](mailto:crisophe.servens@porsche.fr)

#### **Paul Mengel**

Porsche France SA Accounting manager  
25/29, quai Aulagnier  
92600 Asnières-sur-Seine  
Phone: + 33 (0) 1 57 65 89 04  
Mail: [paul.mengel@porsche.fr](mailto:paul.mengel@porsche.fr)

### **ORECA:**

#### **Laurie Gautier**

Porsche Carrera Cup France manager  
Groupe Oreca  
Siège Social Signes  
83030 Toulon  
Mob: + 33 (0) 6 87 51 99 37  
Mail: [lgautier@oreca.fr](mailto:lgautier@oreca.fr)

#### **Benjamin Gauchet**

Porsche Carrera Cup France Technical Manager  
Phone: +33 (0) 6 77 17 84 78  
Mail: [bgauchet.ext@oreca.f](mailto:bgauchet.ext@oreca.f)

### **ORECA Magny-Cours:**

#### **Benjamin CHEVILLARD**

Spare parts Manager  
Groupe Oreca  
Technopole du Circuit  
58470 Magny Cours  
Phone: + 33 (0) 3 86 21 86 10  
Mail: [b.chevillard@oreca-magnycours.fr](mailto:b.chevillard@oreca-magnycours.fr)

### **FFSA:**

#### **André OLIVIER**

Scrutineer FFSA  
Phone: + 33 (0) 6 79 14 11 42  
Mail: [andre.olivier9@wanadoo.fr](mailto:andre.olivier9@wanadoo.fr)

### **Michelin:**

#### **François DOUZON**

Auvergne Pneumatiques  
Phone: +33 (0) 4 73 24 24 24  
Mobile: +33 (0) 6 37 38 50 89  
Mail: [f.douzon@auvergnepneumatiques.com](mailto:f.douzon@auvergnepneumatiques.com)

December 2022 Edition